

A M B I E N C E S
A M B I E N C E S
A M B I E N C E S
A M B I E N C E S
A M B I E N C E S
A M B I E N C E S
A M B I E N C E S
A M B I E N C E S
A M B I E N C E S
A M B I E N C E S
A M B I E N C E S

VENICEM

INDEX	CATEGORY	PAG
OPTICAL SUSPENSION 1	SUSPENDED LAMP	14, 16, 17
OPTICAL SUSPENSION 3	SUSPENDED LAMP	27, 28, 29
OPTICAL TABLE	TABLE LAMP	5, 8, 10
SOUL SUSPENSION	SUSPENDED LAMP	3, 4, 7, 12
TROU SUSPENSION	SUSPENDED LAMP	39, 40, 42
UNIQUE SUSPENSION	SUSPENDED LAMP	35, 36
BLADE COFFEE TABLE	SMALL TABLE	4, 18, 20, 22
RING COFFEE TABLE	SMALL TABLE	39, 42, 43, 44
ROCK COFFEE TABLE	SMALL TABLE	27, 29, 30, 32, 34
SERGE TABLE	TABLE	12
SERGE CABINET	CABINET	5, 8
TECHNICAL DATA		45

AMBIENCE #1





BLADE COFFEE TABLE

SOUL SUSPENSION





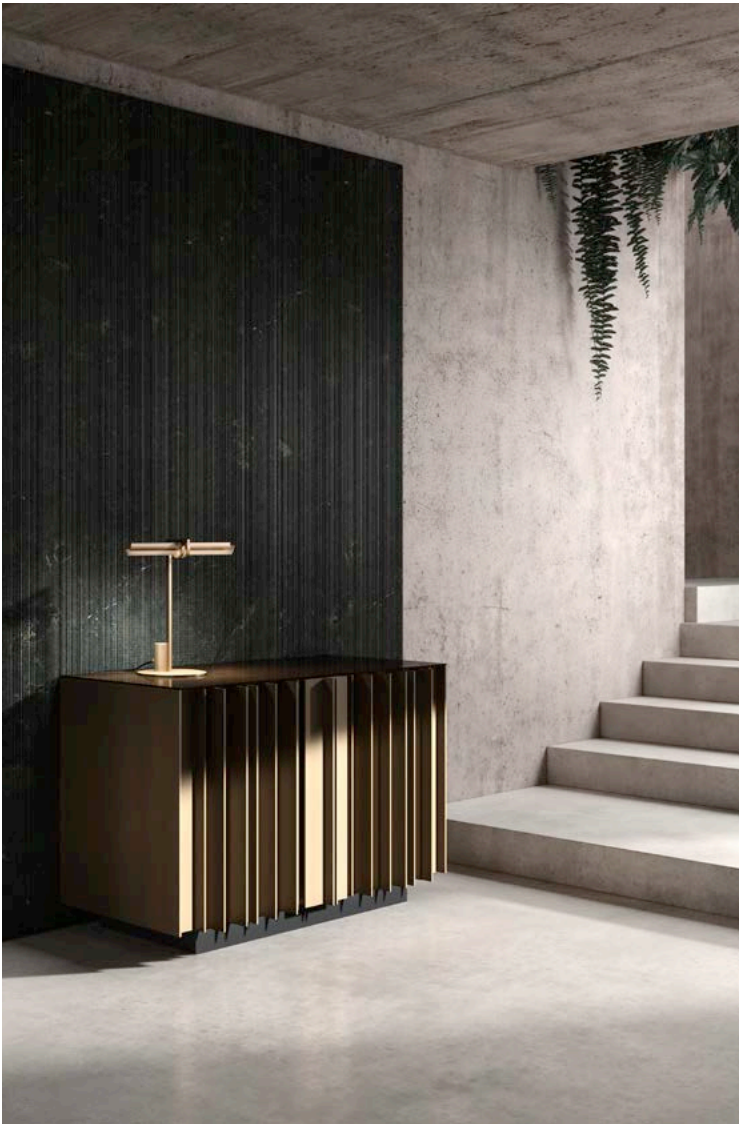

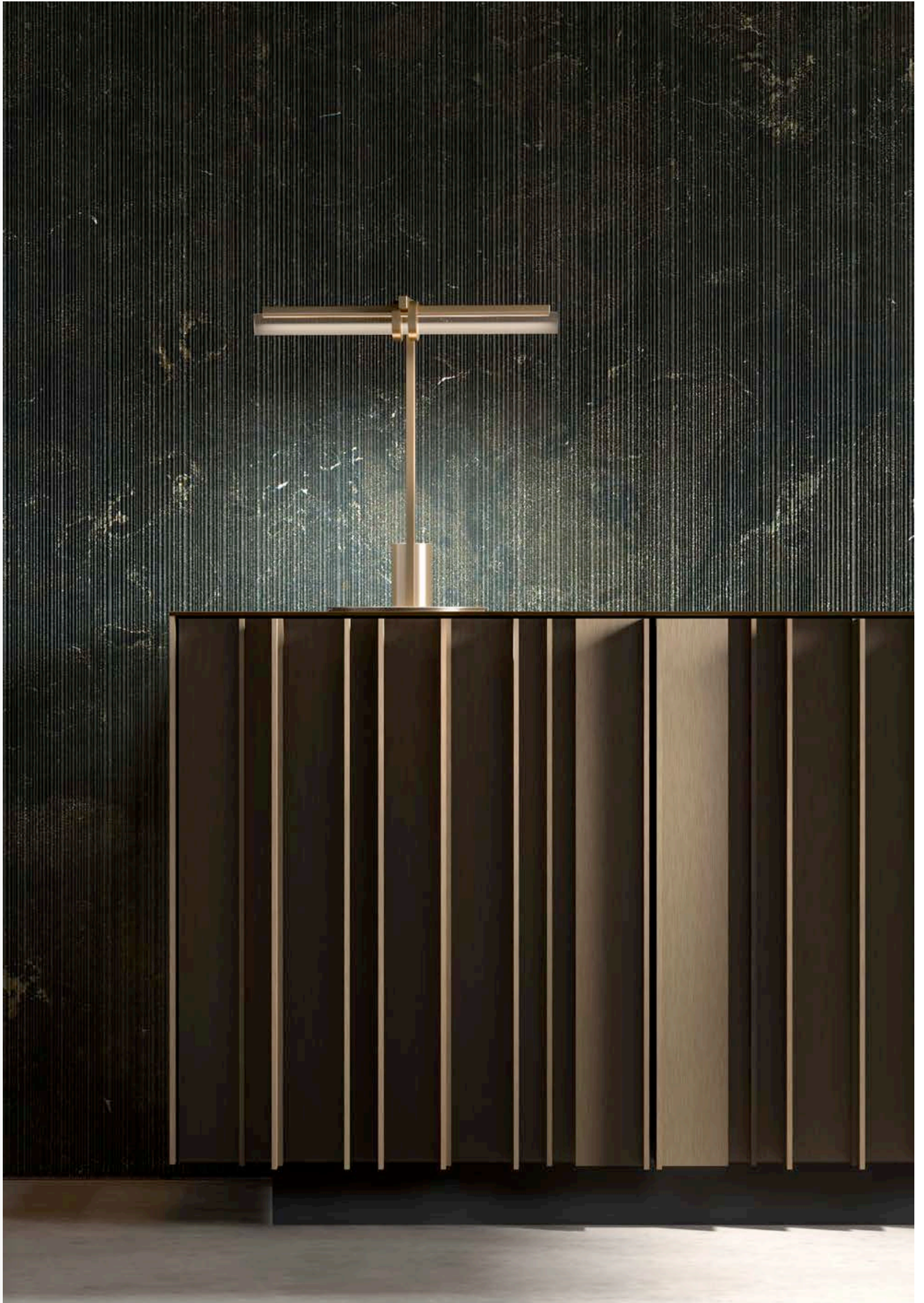























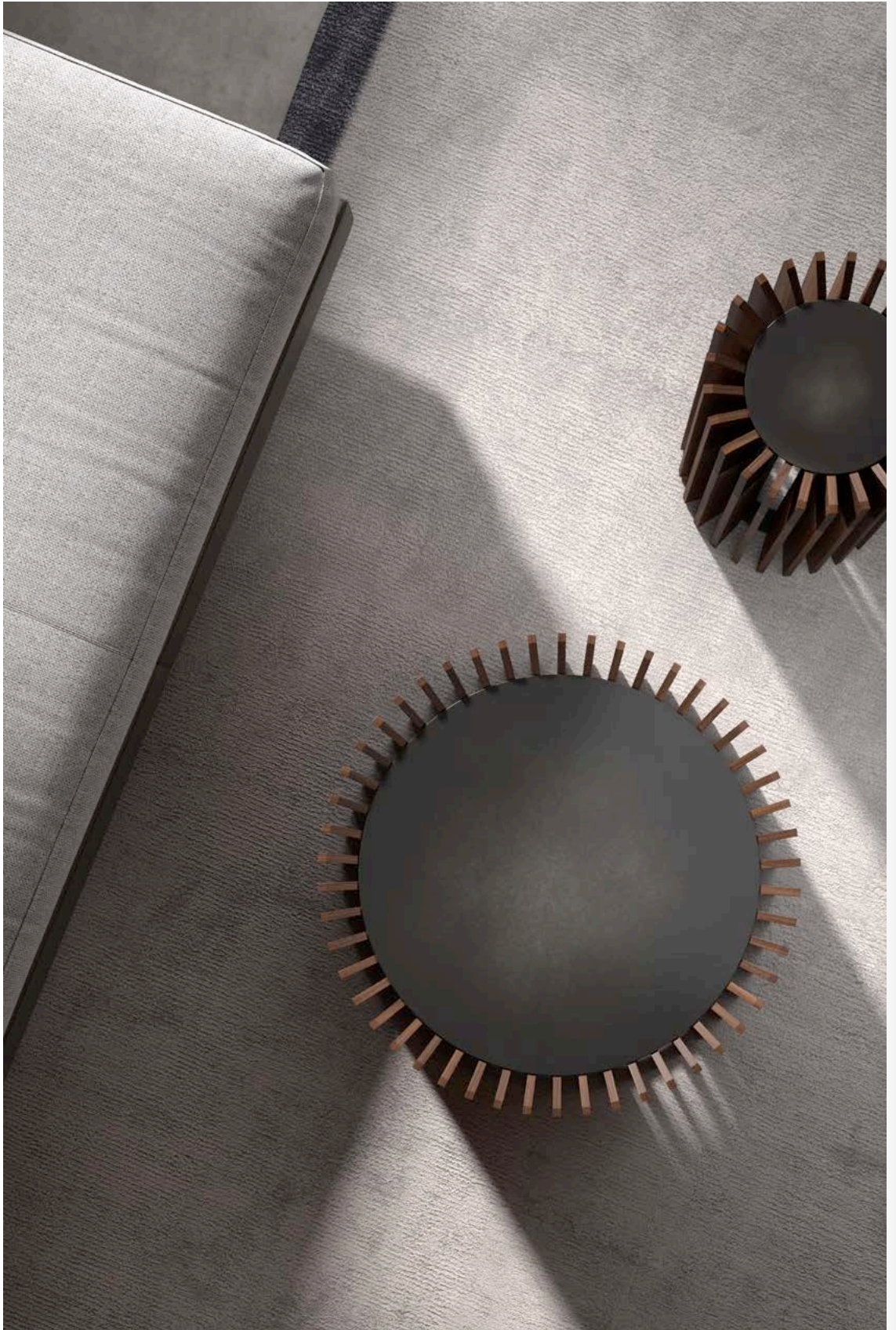

AMBIENCES

MASSIMO TONETTO
Head of design Venicem

Uno Spirito Nuovo muove l'ultima collezione Venicem. Si tratta della naturale evoluzione di un percorso personale e professionale intrapreso e portato avanti negli anni. L'elemento guida resta il simbolo perfetto e armonico insito nelle figure semplici - cerchio, triangolo e quadrato. Questi solidi primordiali, che hanno come fine ultimo quello di rappresentare il principio di universale proporzione, ora si compenetrano, intersecano i loro volumi, costruiscono figure complesse. Il segno invoca una purezza formale e si spoglia di qualsiasi stilismo decorativo per raggiungere nel progetto l'unione inscindibile tra forme base, tecnica strutturale e materiali nobili. Proprio alla selezione di questi ultimi viene dedicata una cura minuziosa. Vetro soffiato, marmo travertino a foro aperto, noce canaletto si abbinano alla tecnica artigiana di brunitura dell'ottone e del ferro. La matericità imperfetta che ne deriva caratterizza le superfici lavorate e restituisce autentici esempi di luce e arredi scultura.

Venicem's latest collection is moved by a *New Spirit*. This is the natural evolution of a personal and professional journey undertaken and carried forward over the years. The guiding element remains the perfect and harmonious symbol inherent in simple figures - circle, triangle and square. These primordial objects, which have as their ultimate goal to represent the principle of universal proportion, now interpenetrate, intersect their volumes, and construct complex figures. The sign invokes a formal purity and sheds any decorative style, in order for the design to achieve an inseparable union of basic forms, structural technique and noble materials. The selection of which is carried out with the utmost care. Blown glass, open-hole travertine marble, and canaletto walnut are combined with artisanal brass and iron burnishing techniques. The resulting imperfect materiality characterizes the finished surfaces, and provides authentic examples of light and sculptured furnishings.

AMBIENCE #2













ROCK COFFEE TABLE

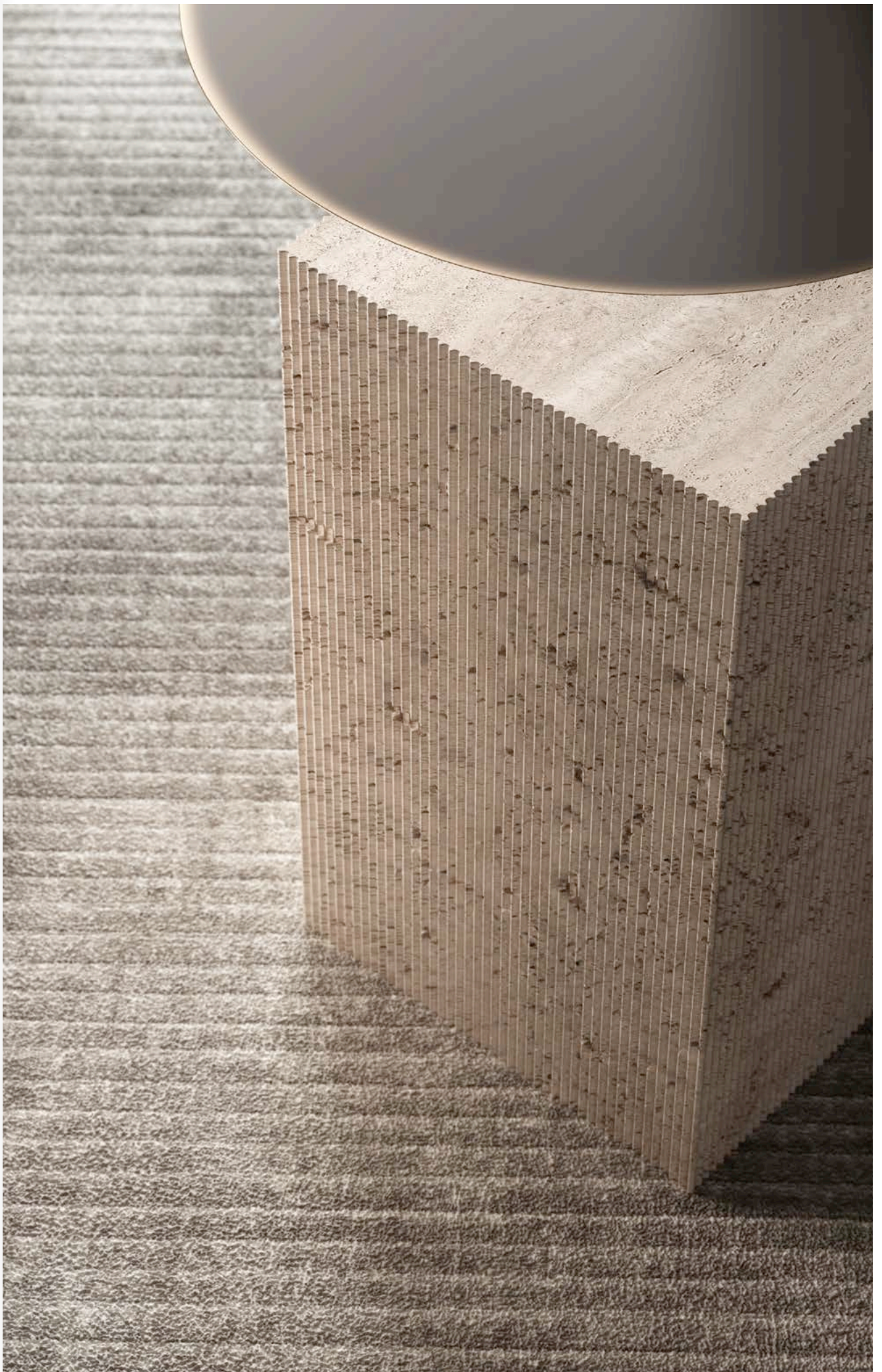



ROCK COFFEE TABLE

















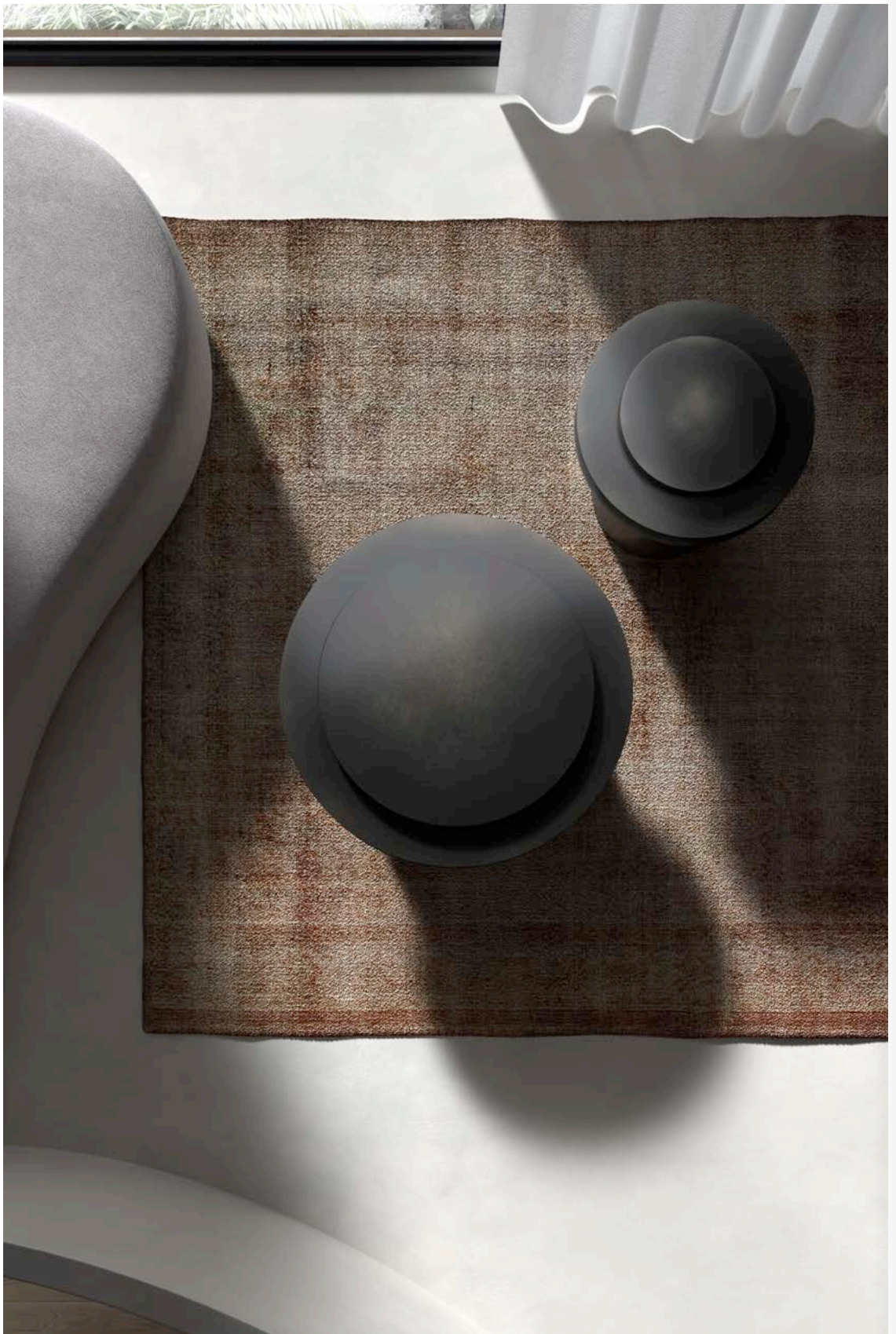

TECHNICAL DATA

OPTICAL SUSPENSION 1

Lampada a sospensione a luce diffusa. Struttura in ottone naturale brunito e diffusore con triedro color cristallo, grigio fumè o ambra. Sospesa con cavi d'acciaio a sistema di fissaggio rapido.

Suspended lamp with diffused light. Natural burnished brass structure and crystal, smoke grey or amber glass trihedron. Suspended with steel cables with rapid fixing system.

SUSPENDED LAMP

P. 14, 16, 17

1x25W strip LED 24V 1976lm 2700°K Dimmable

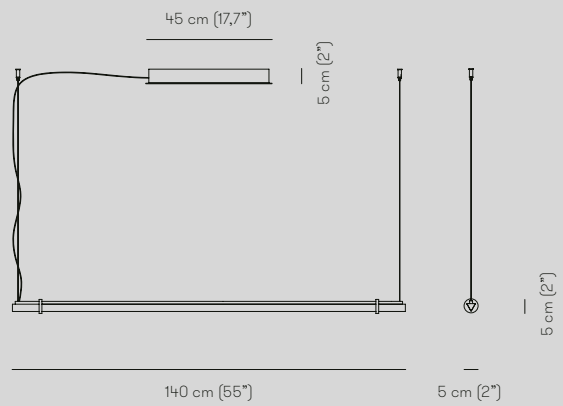

OPTICAL SUSPENSION 3

Lampada a sospensione a luce diffusa. Struttura in ottone naturale brunito e diffusori con triedri color cristallo, grigio fumè o ambra. Sospesa con cavi d'acciaio a sistema di fissaggio rapido.

Suspended lamp with diffused light. Natural burnished brass structure and crystal, smoke grey or amber glass trihedrons. Suspended with steel cables with rapid fixing system.

SUSPENDED LAMP

P. 27, 28, 29

3x19,2W strip LED 24V 4560lm 2700°K Dimmable

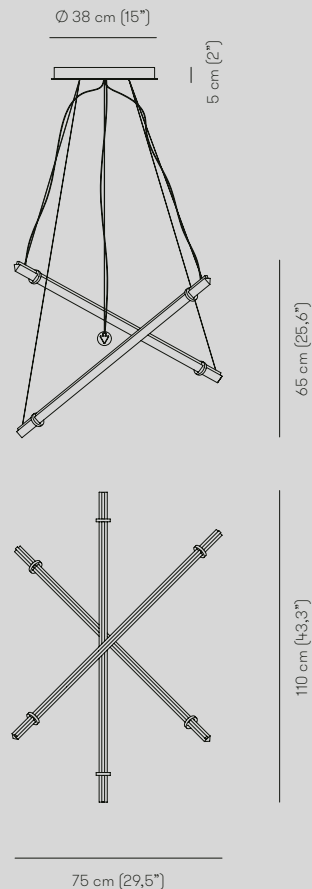

OPTICAL TABLE

Lampada da tavolo a luce diffusa.
Struttura in ottone naturale brunito
e diffusore con triedro color cristallo,
grigio fumè o ambra.

Table lamp with diffused light.
Natural burnished brass structure
and crystal, smoke grey or amber
glass trihedron.

TABLE LAMP

P. 5, 8, 10

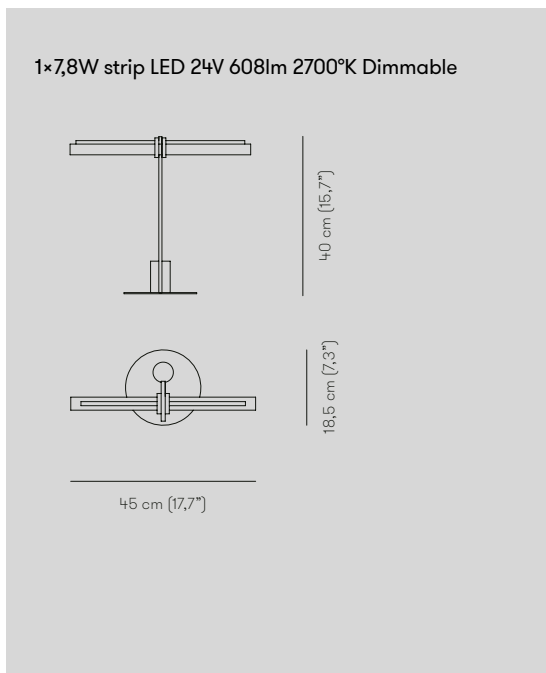

SOUL SUSPENSION

Lampada a sospensione a luce
diffusa. Struttura in ottone brunito
chiaro o nero opaco. Diffusori in
vetro trasparente sabbato.

Suspended lamp with diffused light.
Light burnished brass or matte
black structure. Transparent satin
glass diffusers.

SUSPENDED LAMP

P. 3, 4, 7, 12

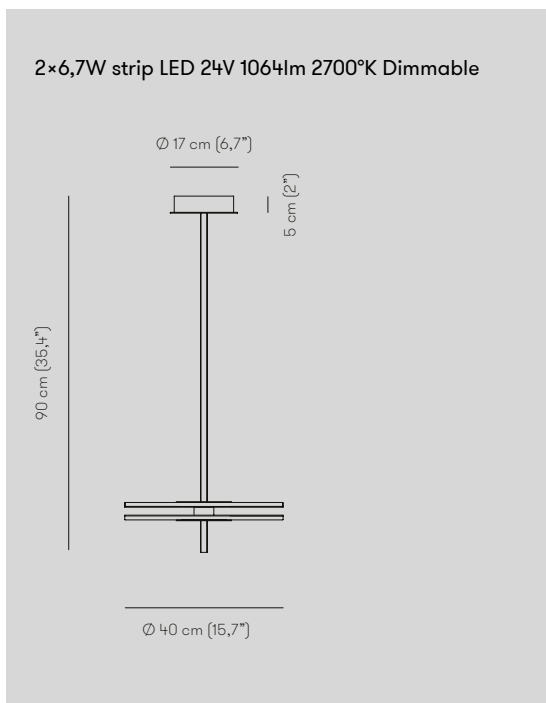

TROU SUSPENSION

Lampada a sospensione a luce diffusa. Struttura in ottone brunito chiaro o metallo nero opaco. Diffusore in vetro soffiato color tortora trasparente o bianco lucido.

Suspended lamp with diffused light. Light burnished brass or matte black structure. Transparent dove grey or polished white blown glass diffuser.

SUSPENDED LAMP

P. 39, 40, 42

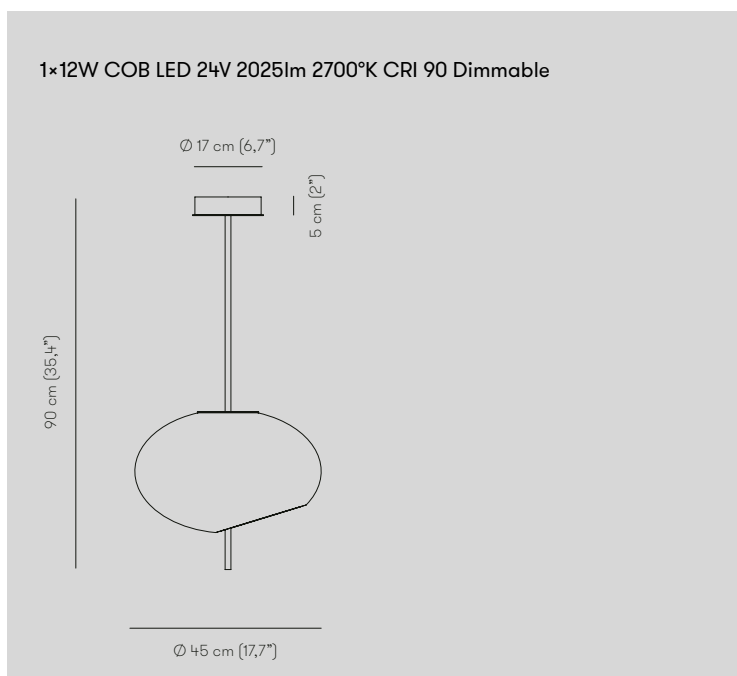

UNIQUE SUSPENSION

Lampada a sospensione a luce diffusa. Struttura in metallo con finitura ottone brunito chiaro o scuro. Diffusori in vetro soffiato bianco lucido, satinato o alabastro ambrato.

Suspended lamp with diffused light. Metal structure, light or dark burnished brass finish. Polished white, satin white, or amber alabaster glass diffusers.

SUSPENDED LAMP

P. 35, 36

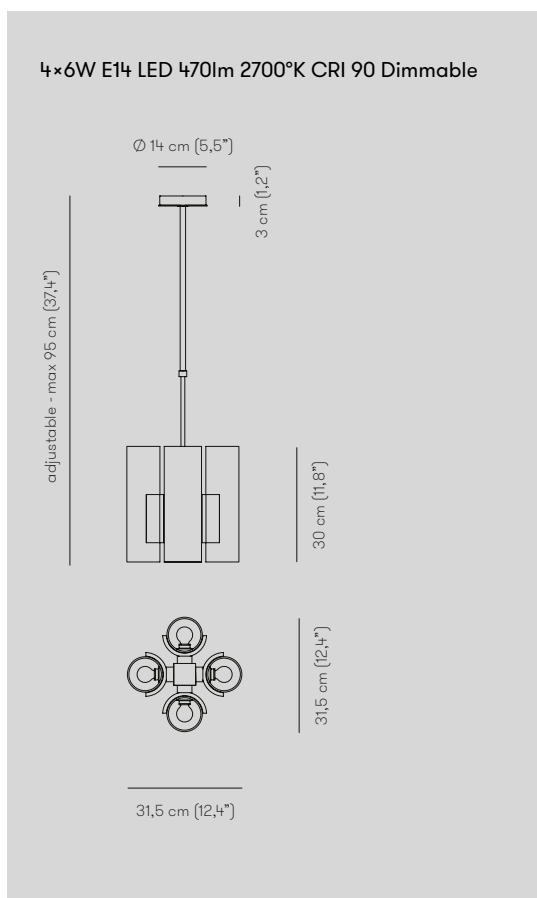

BLADE COFFEE TABLE

Tavolino con struttura in metallo nero, lame in massello noce canaletto opaco e top in ottone brunito sfumato o metallo brunito sfumato.

Coffee table composed by black metal structure, matte canaletto walnut solid wood blades and blended burnished brass or blended burnished metal top.

SMALL TABLE

P. 4, 18, 20, 22

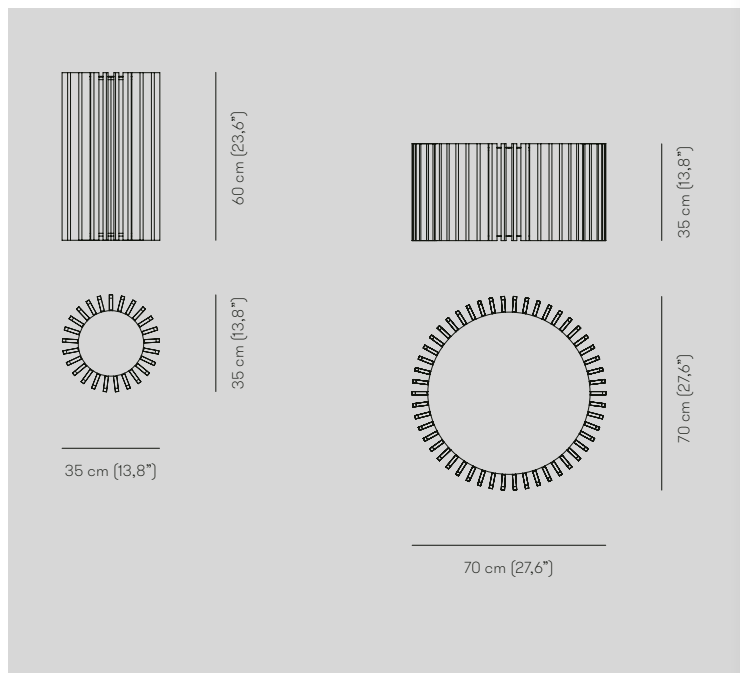

RING COFFEE TABLE

Tavolino con struttura in metallo brunito sfumato.

Coffee table composed by a blended burnished metal structure.

SMALL TABLE

P. 39, 42, 43, 44

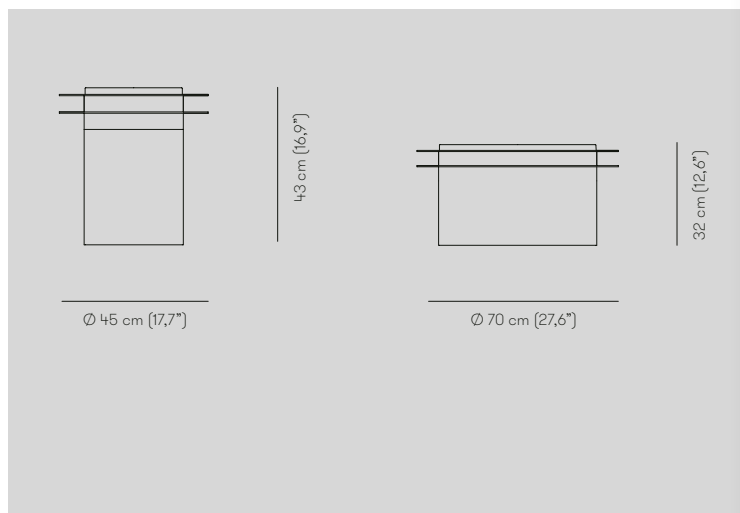

ROCK COFFEE TABLE

Tavolino con struttura portante in marmo travertino rigato, a foro aperto e top e parti a vista in metallo con finitura ottone brunito scuro.

Coffee table composed by an open pore striped travertine marble main structure and metal top and exposed parts in dark burnished or delabr  brass finish.

SMALL TABLE

P. 27, 29, 30, 32, 34

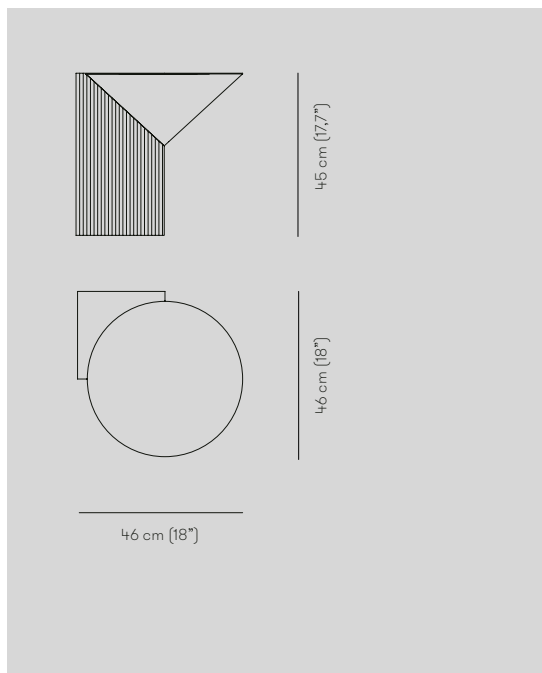

SERGE TABLE

Tavolo in metallo con finitura bronzo striato scuro e top in specchio bronzo antichizzato.

Metal table with dark bronze striped finish and antique bronze mirror top.

TABLE

P. 12

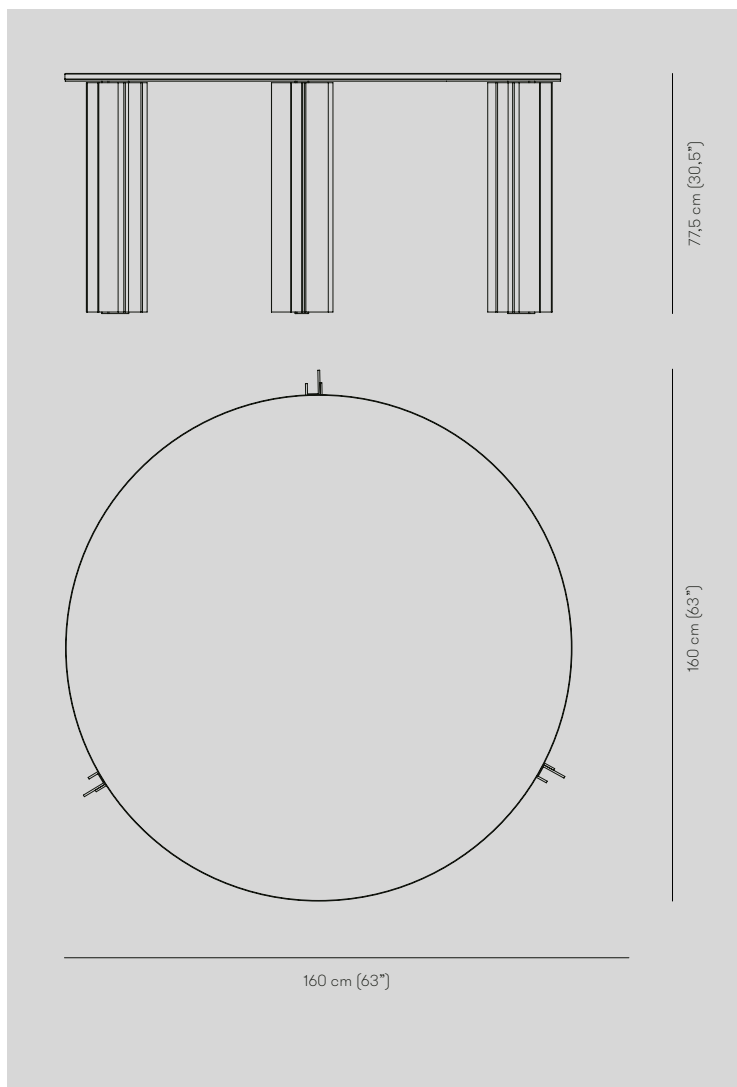

SERGE CABINET

Madia con profili in alluminio, finitura in bronzo striato scuro e scocca in laccato nero opaco. Top in vetro specchio bronzo antichizzato.

Madia composed of aluminium profiles, bronze finish and matte black lacquered body. Bronze antique mirror glass top.

CABINET

P. 5, 8

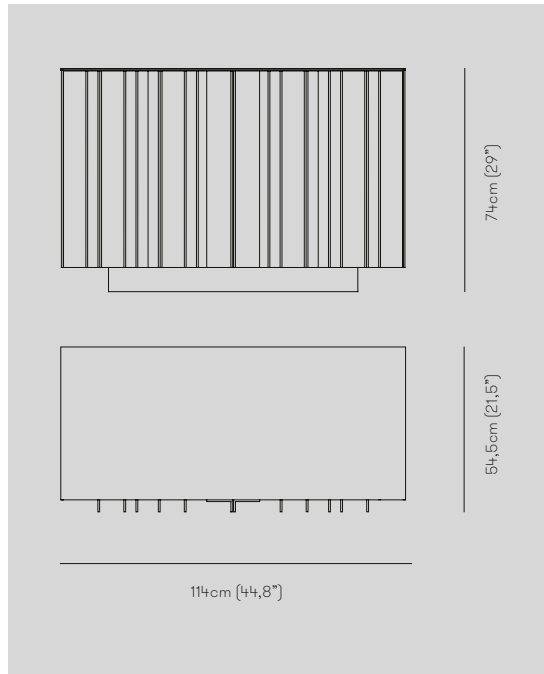

VENICEM S.R.L.

via Terraglio, 54
31021 Magliano Veneto (TV)
Italy

T / F (+39) 041 593 6143
info@venicem.com
www.venicem.com

Creative Direction
Ottone Studio

Graphic Design
Ottone Studio

Production
Link

Print
Grafiche Antiga

February 2022

VeniceM si riserva il diritto di apportare, senza preavviso, ogni modifica mirata al miglioramento funzionale e qualitativo dei prodotti. Testi e disegni presenti in questo stampato hanno scopo divulgativo; per ogni aspetto tecnico e dimensionale fare riferimento ai listini aziendali e relativi aggiornamenti. I campioni di colore e materiali hanno valore indicativo.

VeniceM reserves the rights at all time to apply modifications for the functional or qualitative improvement of its products. Texts and drawings present in this brochure have a divulgative purpose: for every technical and dimensional aspect please refer to the company's price lists and their relative updatings. The colour and material samples have an indicative value.

© VeniceM - Tutti i diritti sono riservati a norma di legge / All rights reserved
Il marchio VeniceM è proprietà della VeniceM srl / Trade Mark VeniceM

VENICEM.COM