

ANDCOSTA

LOOK BOOK 22

LIGHT  
DESIGN  
AND  
MULTIPLE  
POINTS  
OF VIEW

The image features a dark grey background. In the center, there is a large, vibrant red circle. Overlapping the bottom right portion of this circle is a red triangle pointing downwards. The text 'LIGHT DESIGN AND MULTIPLE POINTS OF VIEW' is written in a bold, dark grey, sans-serif font, stacked vertically and centered over the graphic elements.



**LOOK BOOK 22**





VALUE #1



## LIGHT DESIGN AND MULTIPLE POINTS OF VIEW

Lighting design is a fundamental aspect of planning architectural spaces that are inspired by aesthetic comfort. We design indoor and outdoor lighting units for residential and commercial interiors, office spaces and the hospitality industry, as well as for bespoke special projects. From so many perspectives, light can be interpreted as a metaphor capable of influencing everyday life, and there is no doubt that life can be greatly improved through proper lighting.

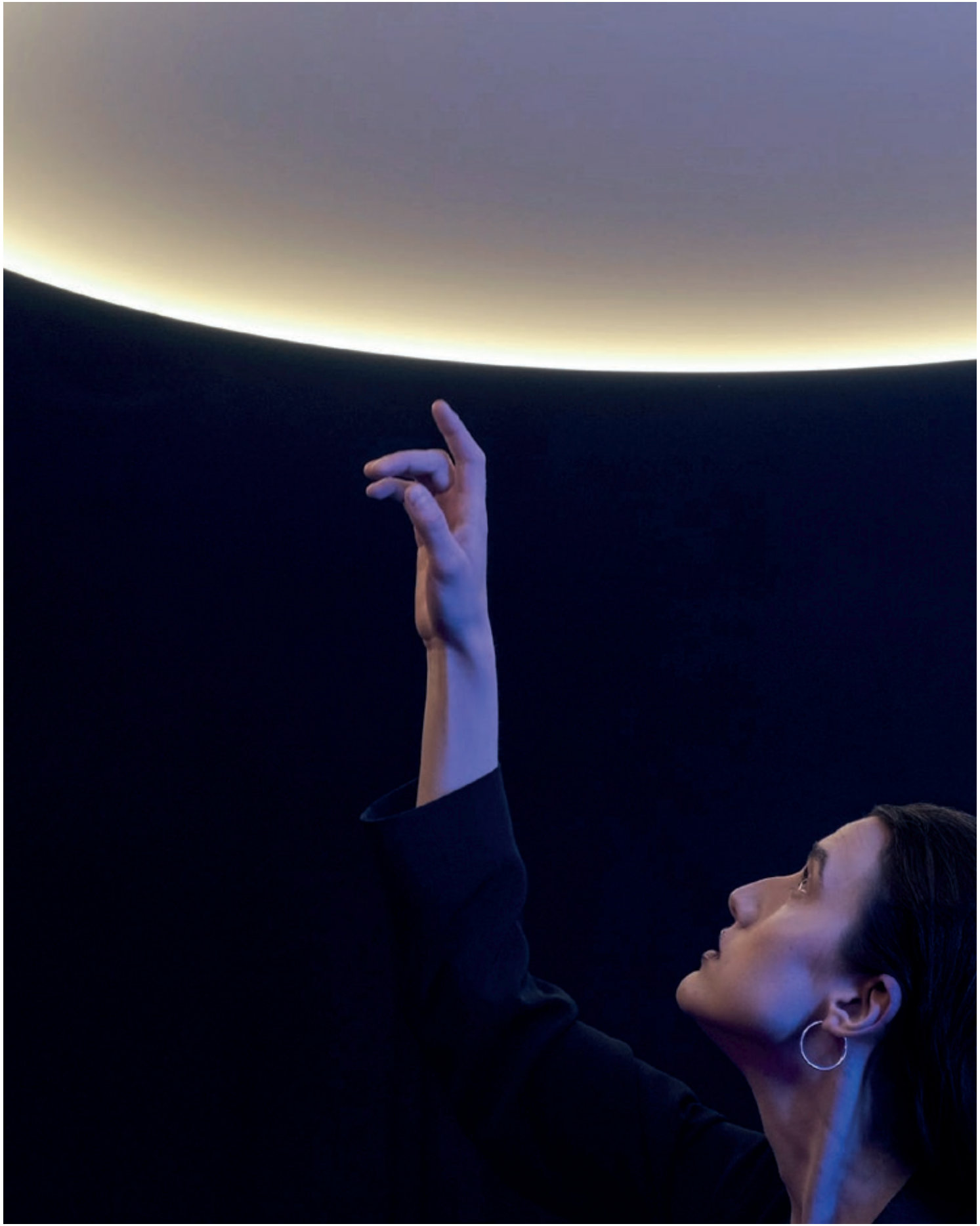

VALUE #2



# BACKGROUND & QUALITY

Our technical expertise merges with influences from the eclectic arts and crafts scene of our region. Our in-depth knowledge of materials and unlimited creative thinking are the foundation of creating a new perspective on Italian lighting product design. Ensuring the quality of products is our priority. We test the resistance and durability of our products, ensuring compliance to the highest international standards of the market.



uniques executions

bespoke tailoring

products catalogue customization

# WE CUSTOMIZE YOUR PROJECT



request



request



size



idea

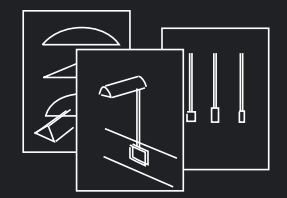

design

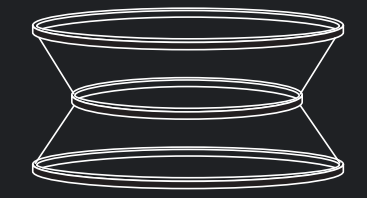

- 3 +

composition



unique realization

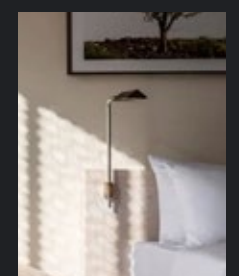

product

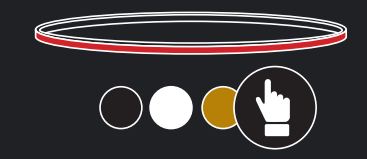

finish

From the initial design concept to the final logistics, our team works alongside our clients at every step, to provide tailored lighting solutions for residential settings, offices and co-working areas, as well as hotels, showrooms and public spaces.

Our skills are maximised in the custom-design and product divisions, where we combine cutting-edge technology with a strong but elegant made in Italy quality.

Our team works with contemporary designers and architects from all over the world to design and develop high-end bespoke projects.





CONCEPT

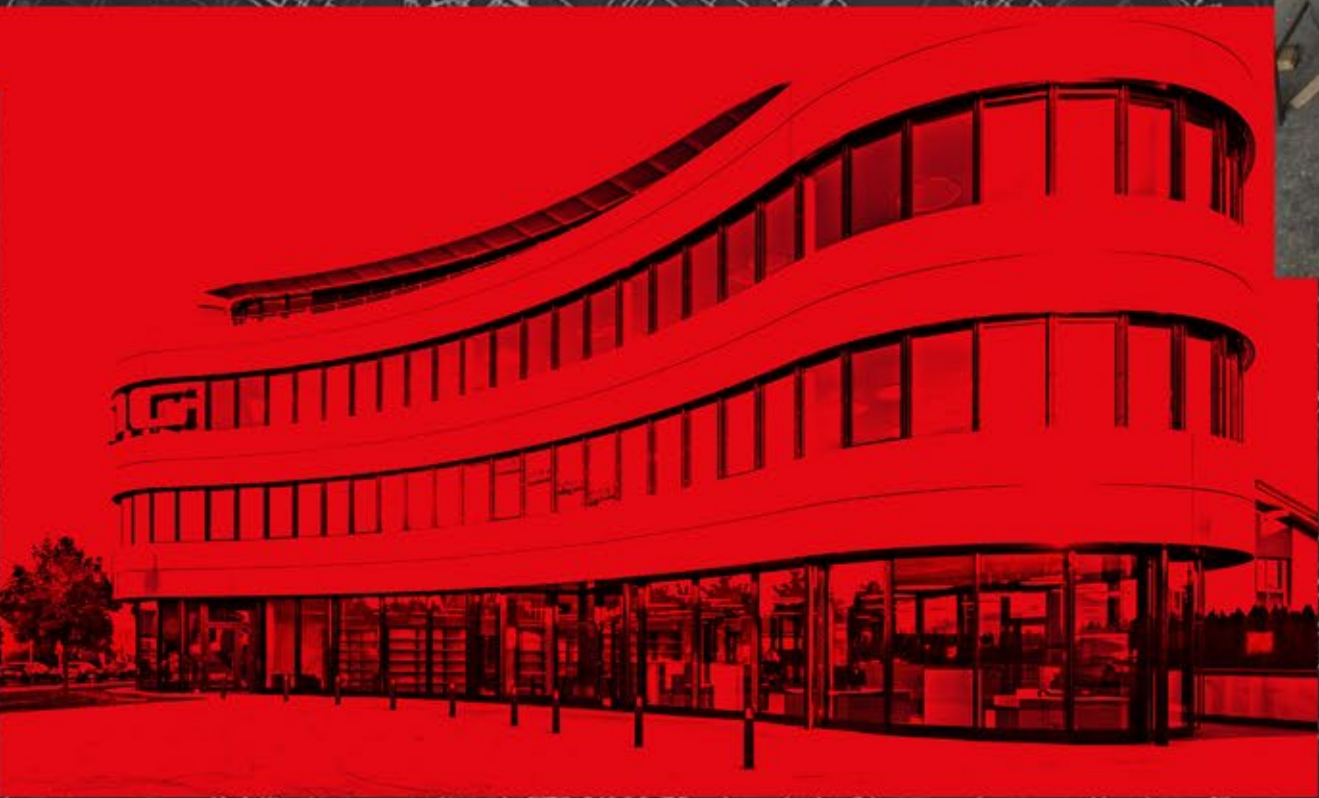

PROJECT

REALIZATION

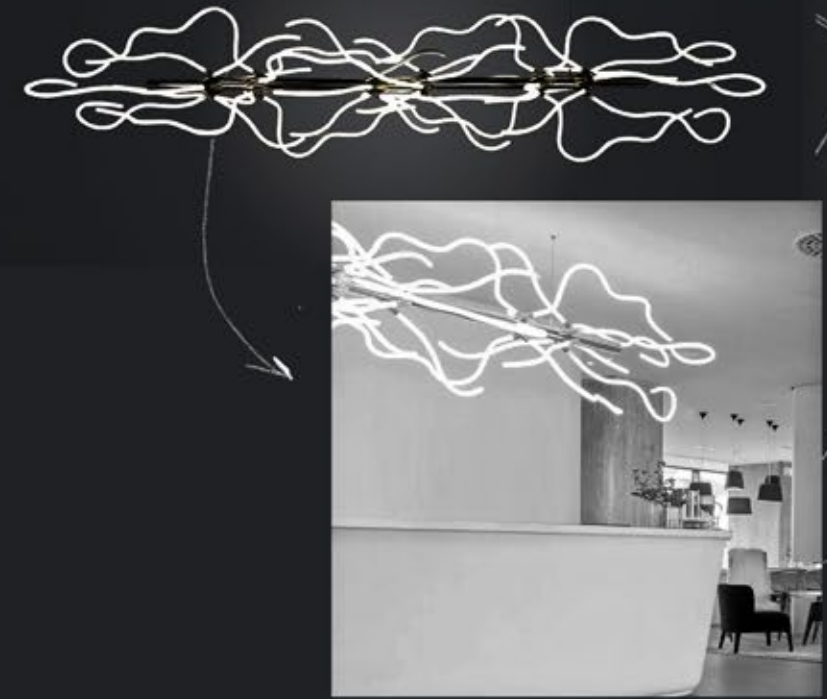

INSTALLATION





## VALUE #4

# ITALIAN HERITAGE & SUSTAINABILITY

As part of our Italian cultural heritage, we take great pride in providing clients with the artisan workmanship inspired by our country's rich history of design, while at the same time enhancing our projects with a modern, functional and built-to-last quality. We choose materials with the utmost care, and we believe in sustainability as an integral part of our Italian Design philosophy.





**VALUE #5**



# LONG-LASTING GOODS

We focus on the production and maintenance of long-lasting goods, because sustainability for us means creating products of high quality that won't need to be replaced. Andcosta supports a design culture that studies functionality, aesthetics and sustainable development.





GRUE, design by Nicolas Stadler

## VALUE #7



# BY YOUR SIDE

Andcosta provides continuous support throughout the entire course of a project and our team is always on hand to provide professional and constructive advice. Each product represents a unique story and is the result of the collaboration between our clients and the designers.

Our online tools are designed to bring our design team closer to the client in a virtual space where they can gather information, deliver bespoke consultations help foster inspiration through visualisation.





VALUE #6

## SOUND- ABSORPTION

A peaceful environment is a basic human need. When we are in a room, all our senses are aroused. There is a strong link between staff productivity, health and a healthy environment. Good acoustics are not just achieved through the physical properties of the environment, such as spatial acoustics, the shape of the room and its layout, but also through the properties of specifically designed devices. Similarly, this technology can be exploited within home, with the use of lamps designed for absorbing sound in different rooms of the house. These lamps represent a new frontier in the realm of lighting, they have been conceived to be not just functional but also holistic.









## LIGHT #1

### CIRCUS

A system for architectural lighting and acoustic control. The circus modular and suspended shapes are the ideal solutions for showrooms, collective areas and workspaces of different dimensions.

design by Carlo Zerbaro









# CIRCUS

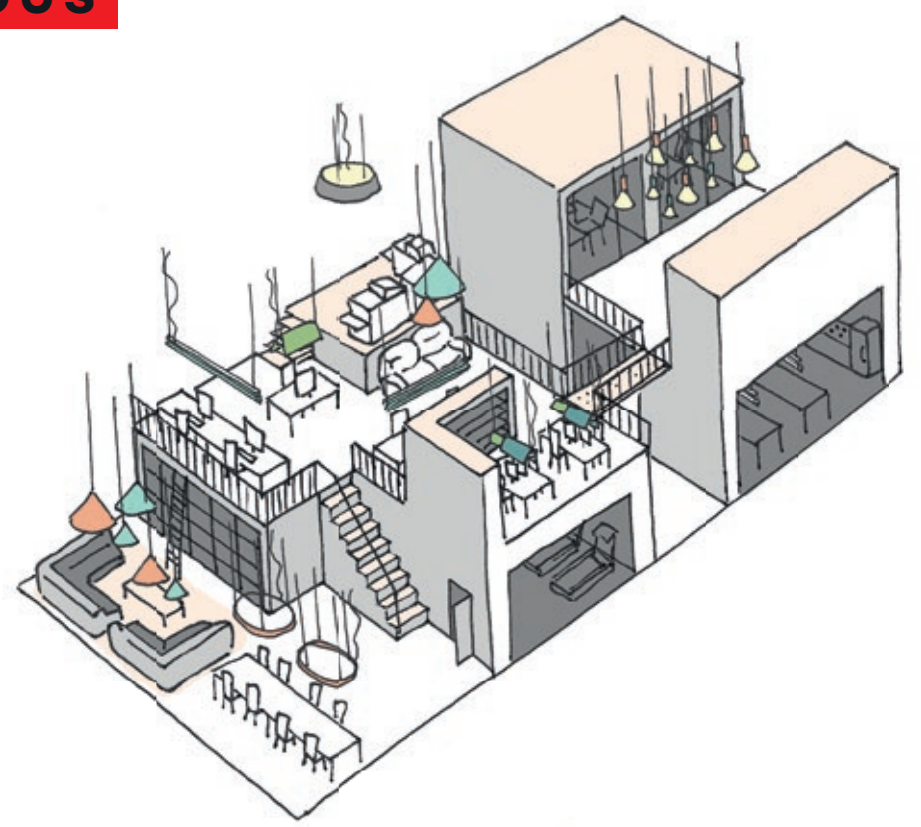



## LIGHT #2

### B-PRO

Technology merges with architecture in sublime lighting with a minimalist expression, offering an infinite number of configuration possibilities. The B-BRO line defines space by tracing elegant geometrics that float in space. Its minimal light source provides multiple options for lighting.

design by Carlo Zerbaro





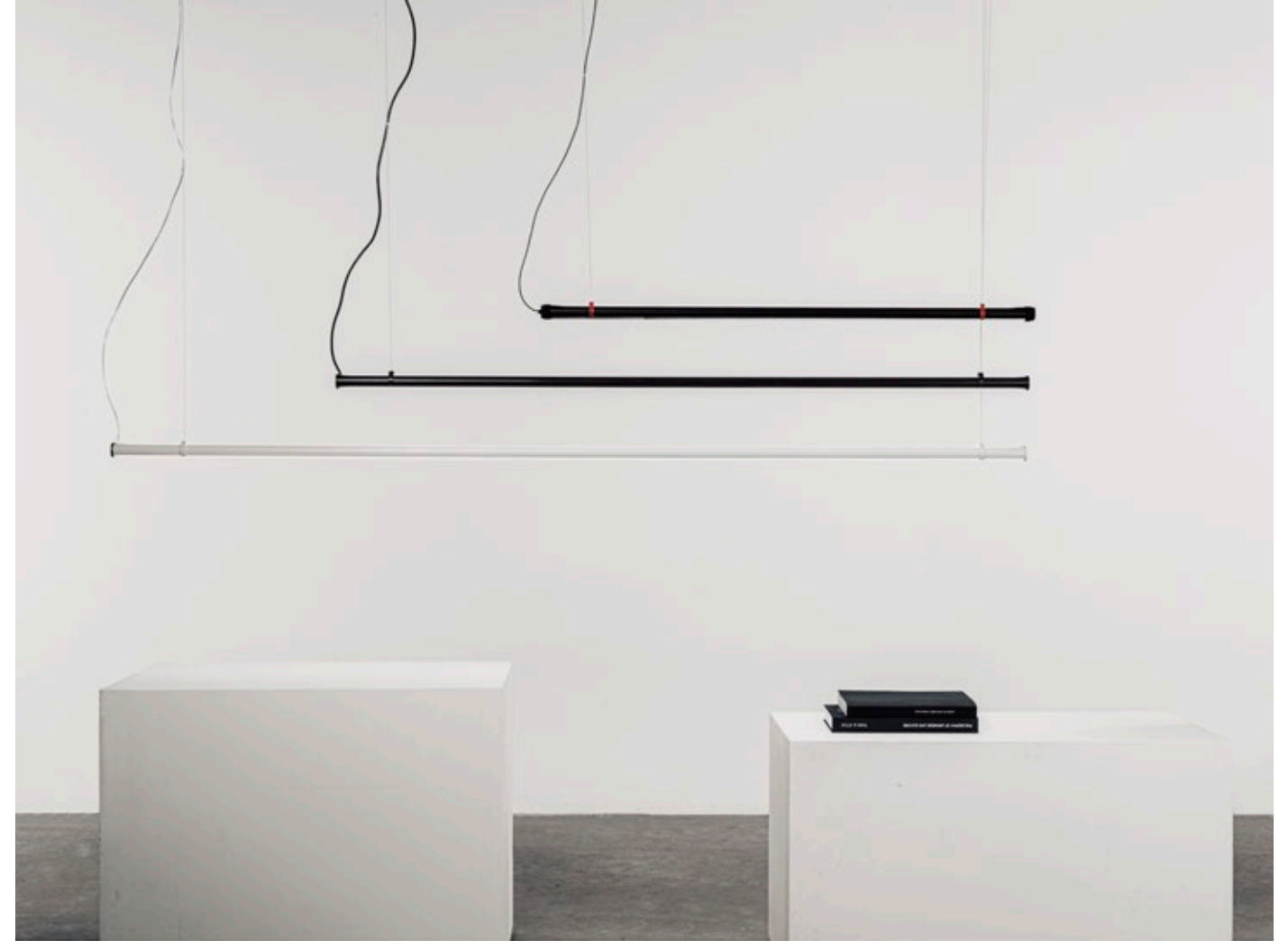
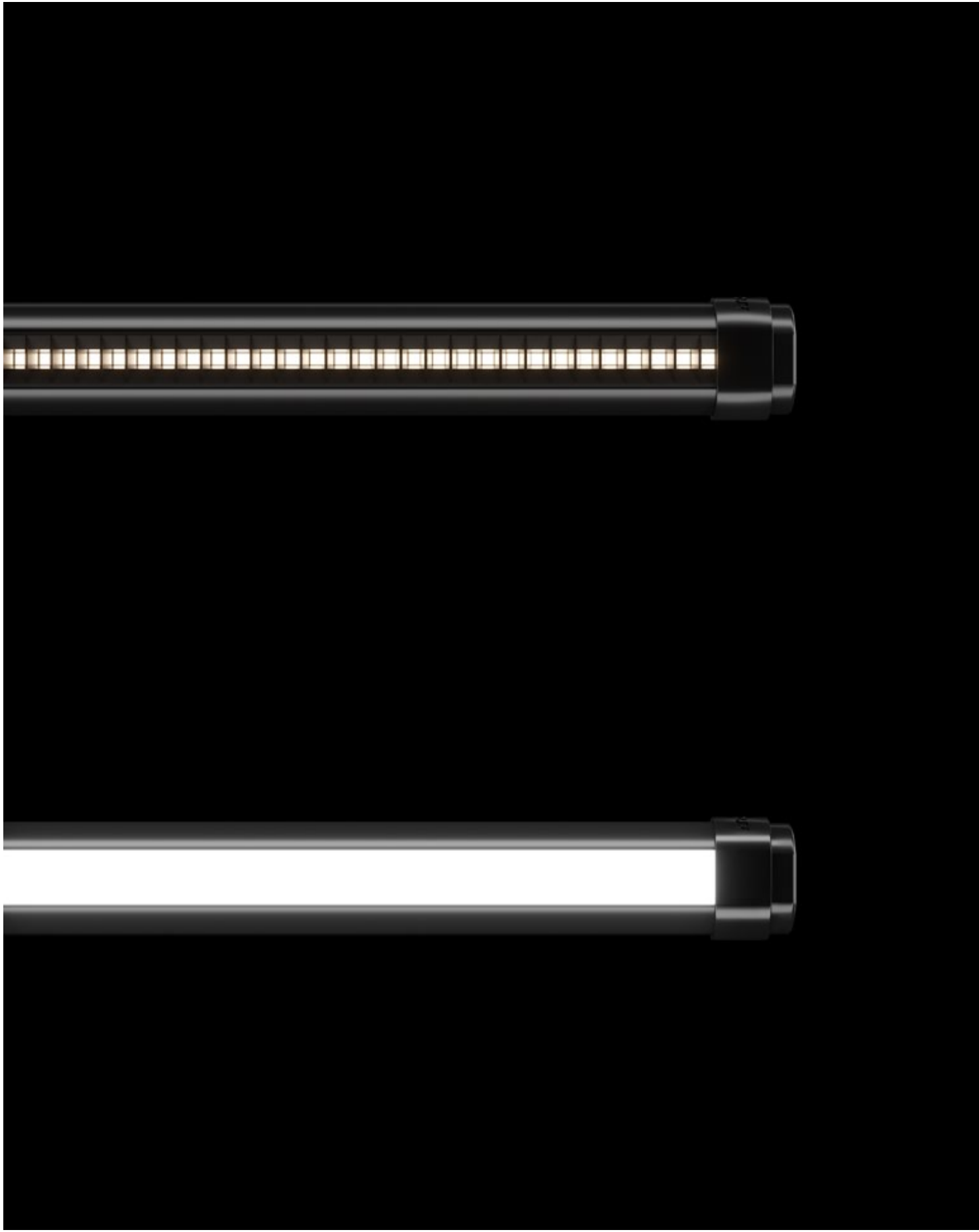





**B-PRO**

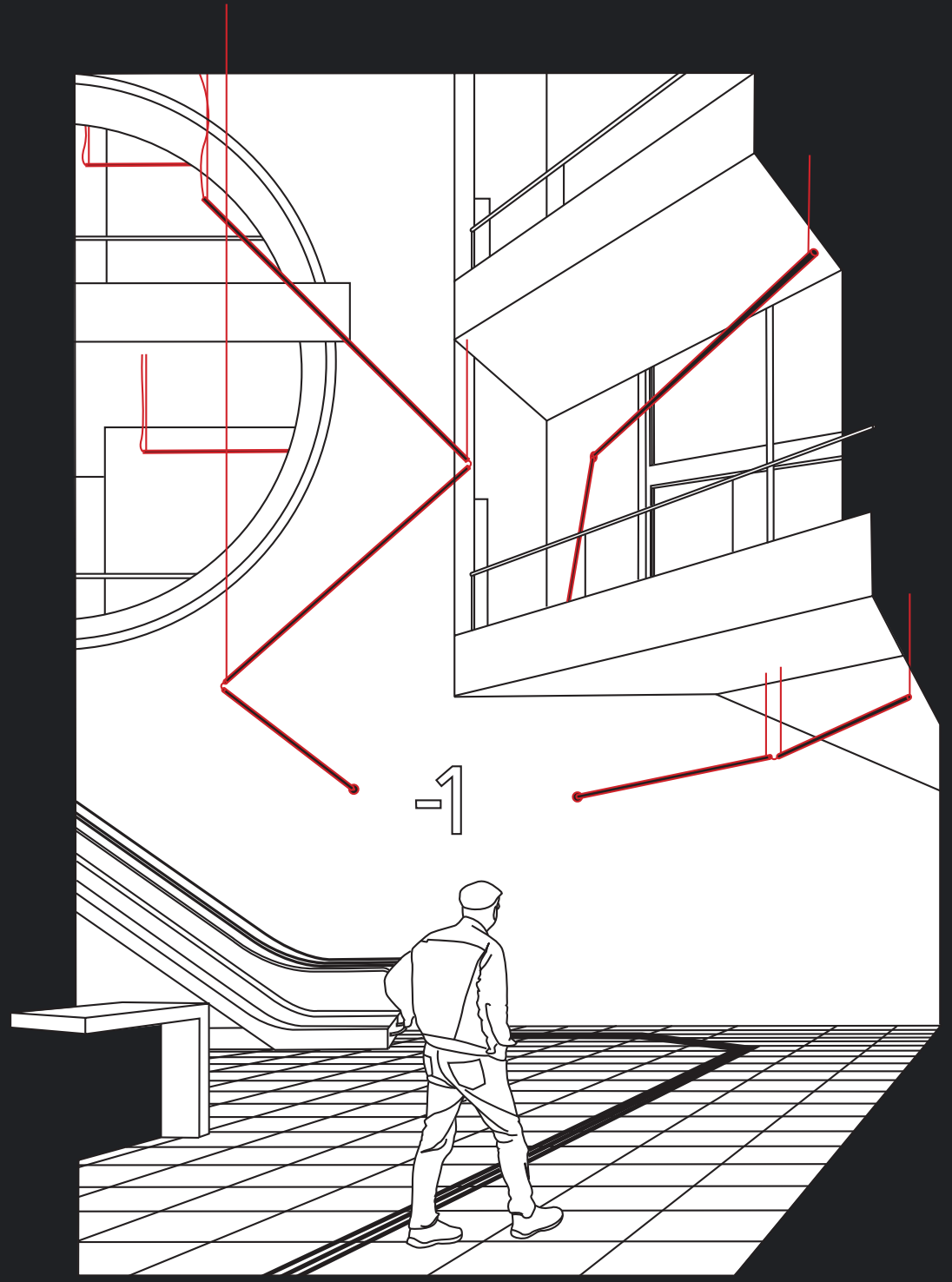

## LIGHT #3

### DAYTONA

Daytona originates from a rail and transforms, creating modular lighting landscapes that suit the user's requirements perfectly. Daytona: the continual evolution of a rail with a versatile, minimal design. Simple movements are all you need to put together your own rails creatively according to your space.

design by Carlo Zerbaro



DAYTONA





# DAYTONA

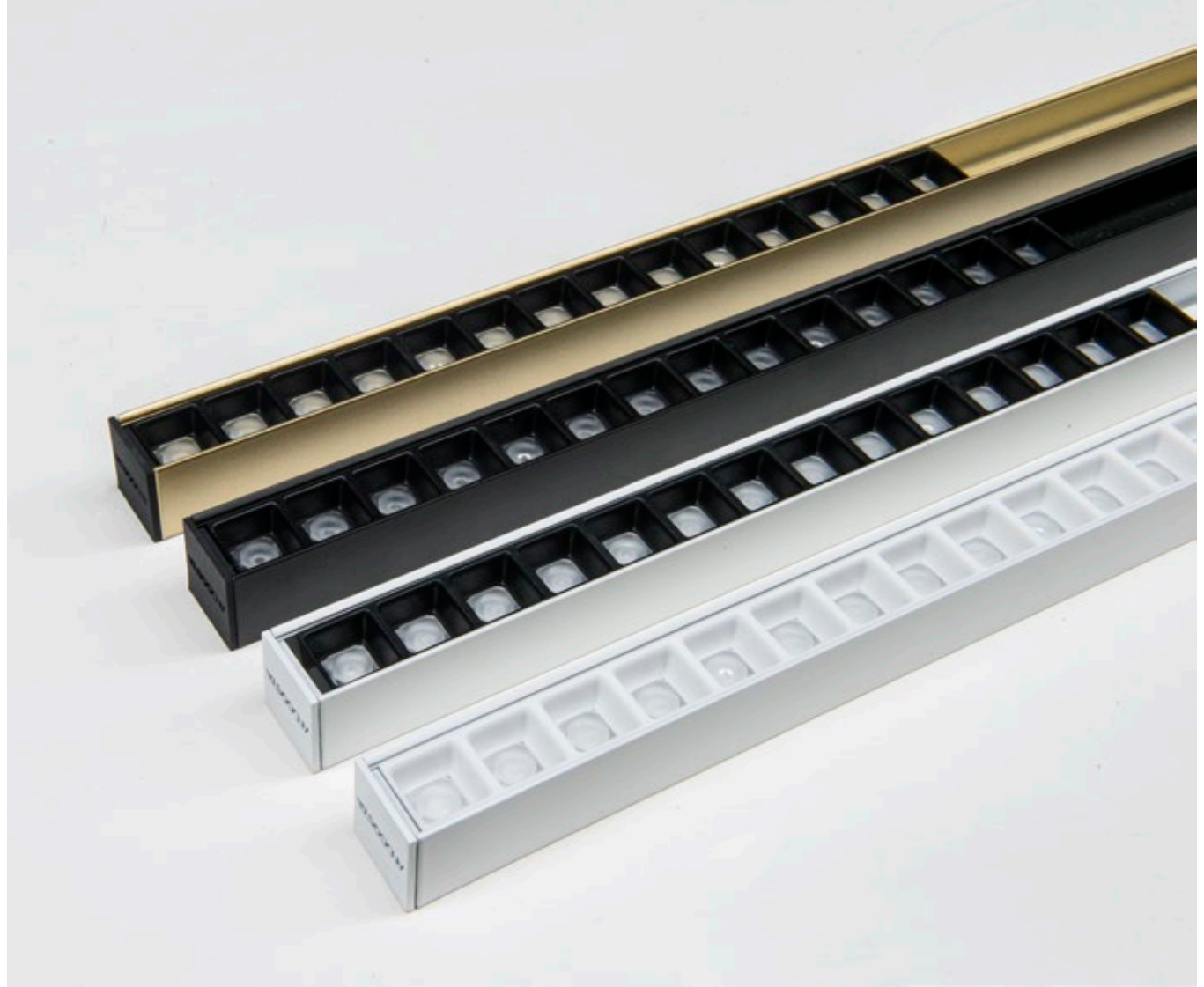
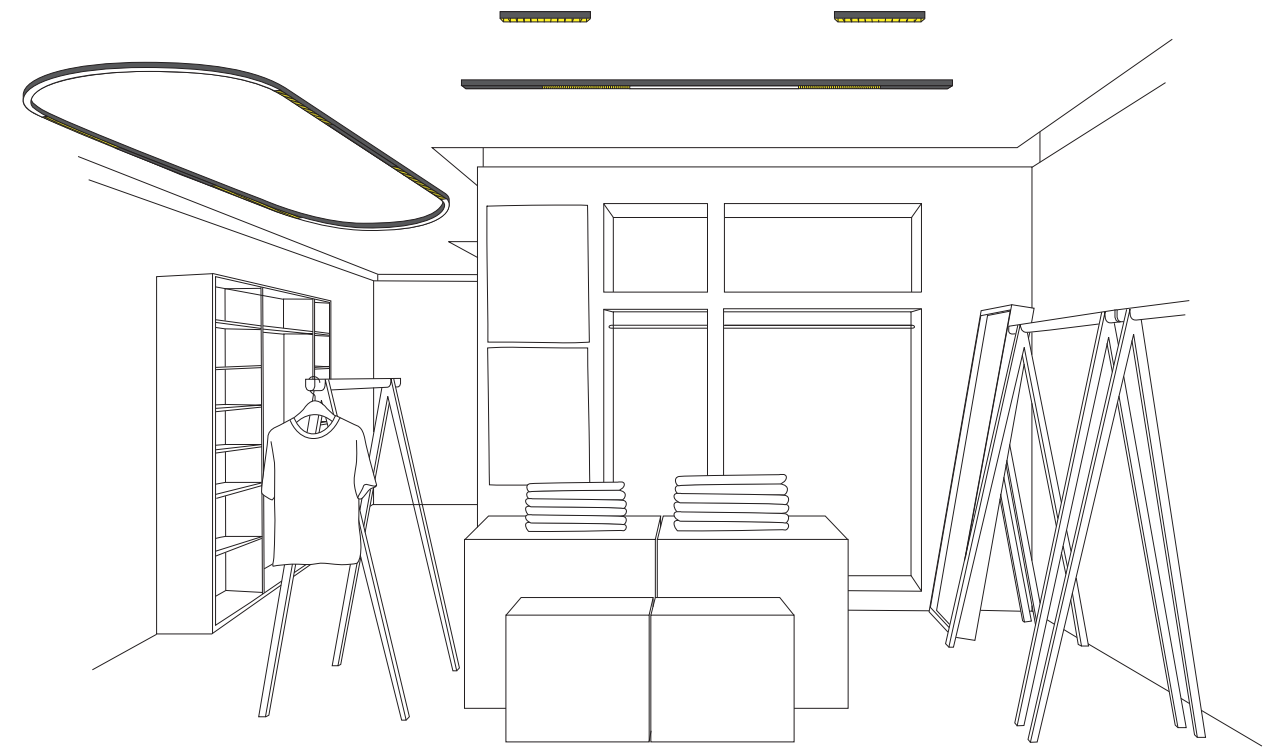
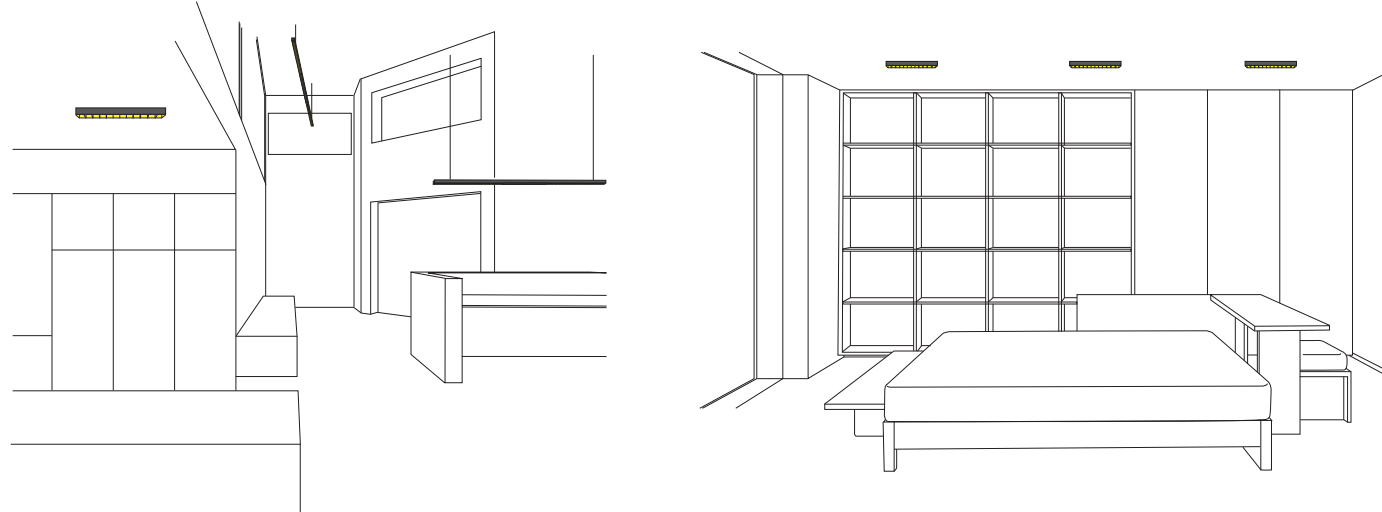



**DAYTONA**



## LIGHT #4

### LUNA

A homage to the pale shape of the moon, Luna is a hanging lamp with both a perceptive shape and meaning. By combining vertical and horizontal installations, the space is transformed in a charming and mysterious environment deeply embedded in our emotional response to this luminous object.







LUNA





**LUNA**

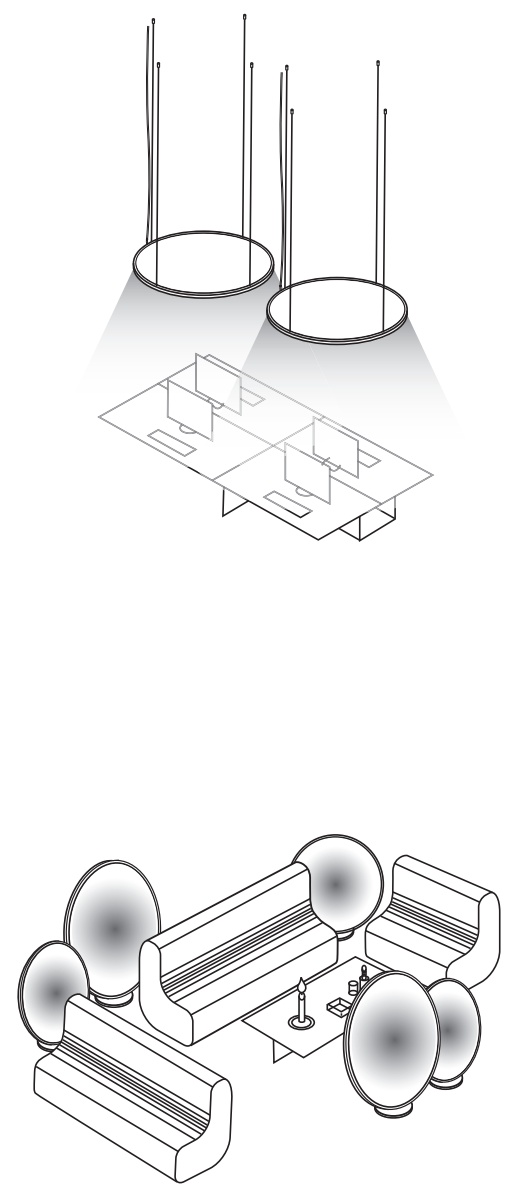
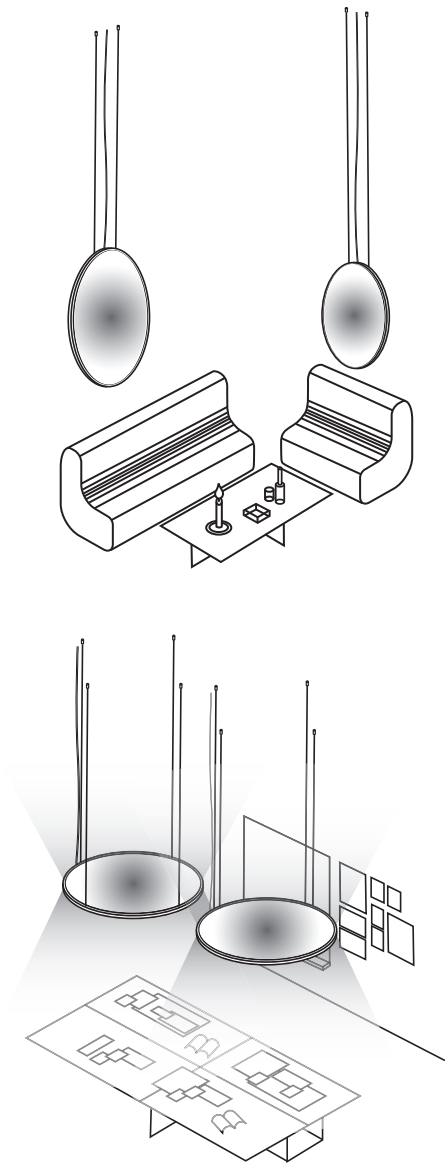



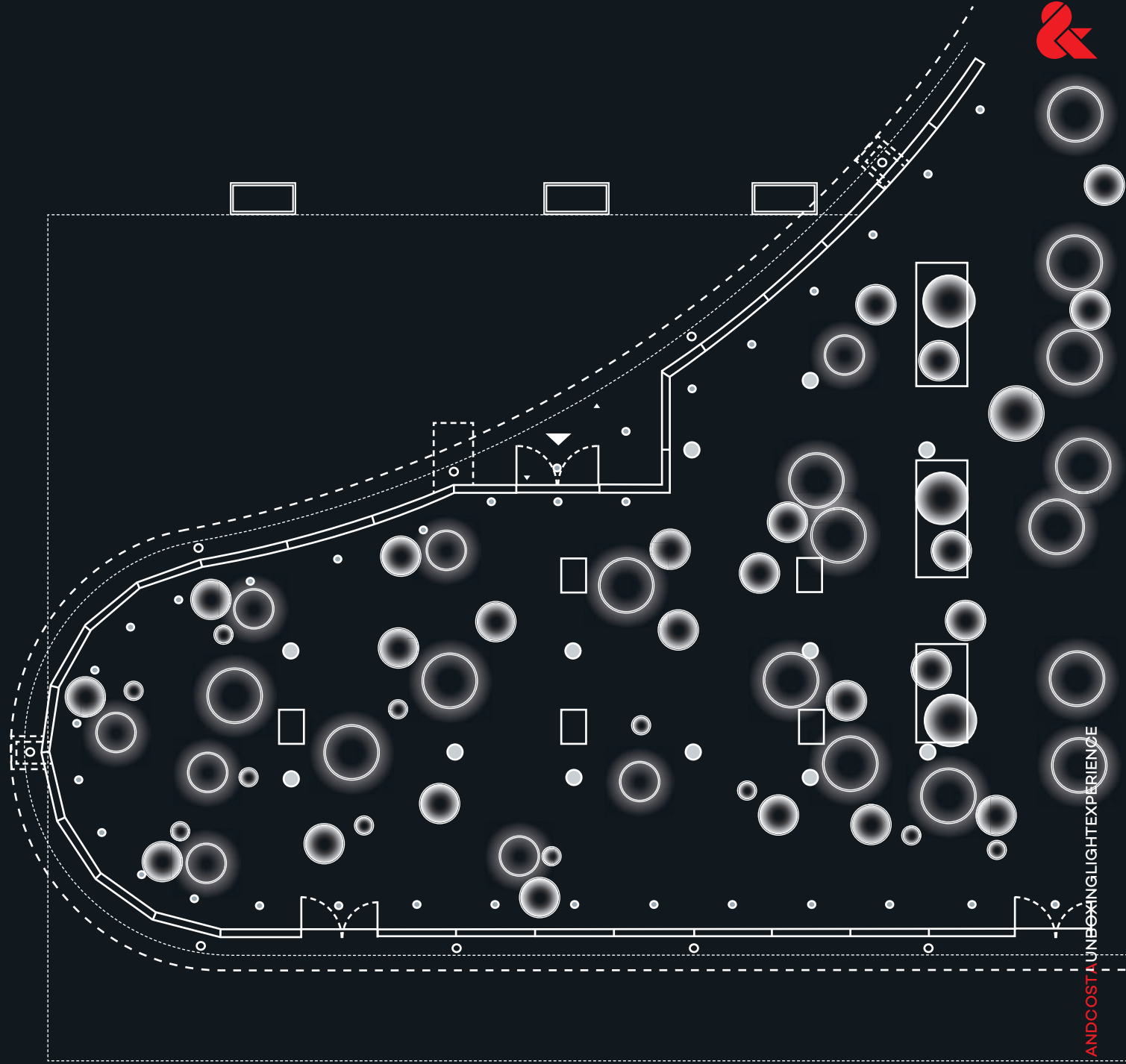

ANDCOSTA UNBOXING LIGHT EXPERIENCE







LUNA

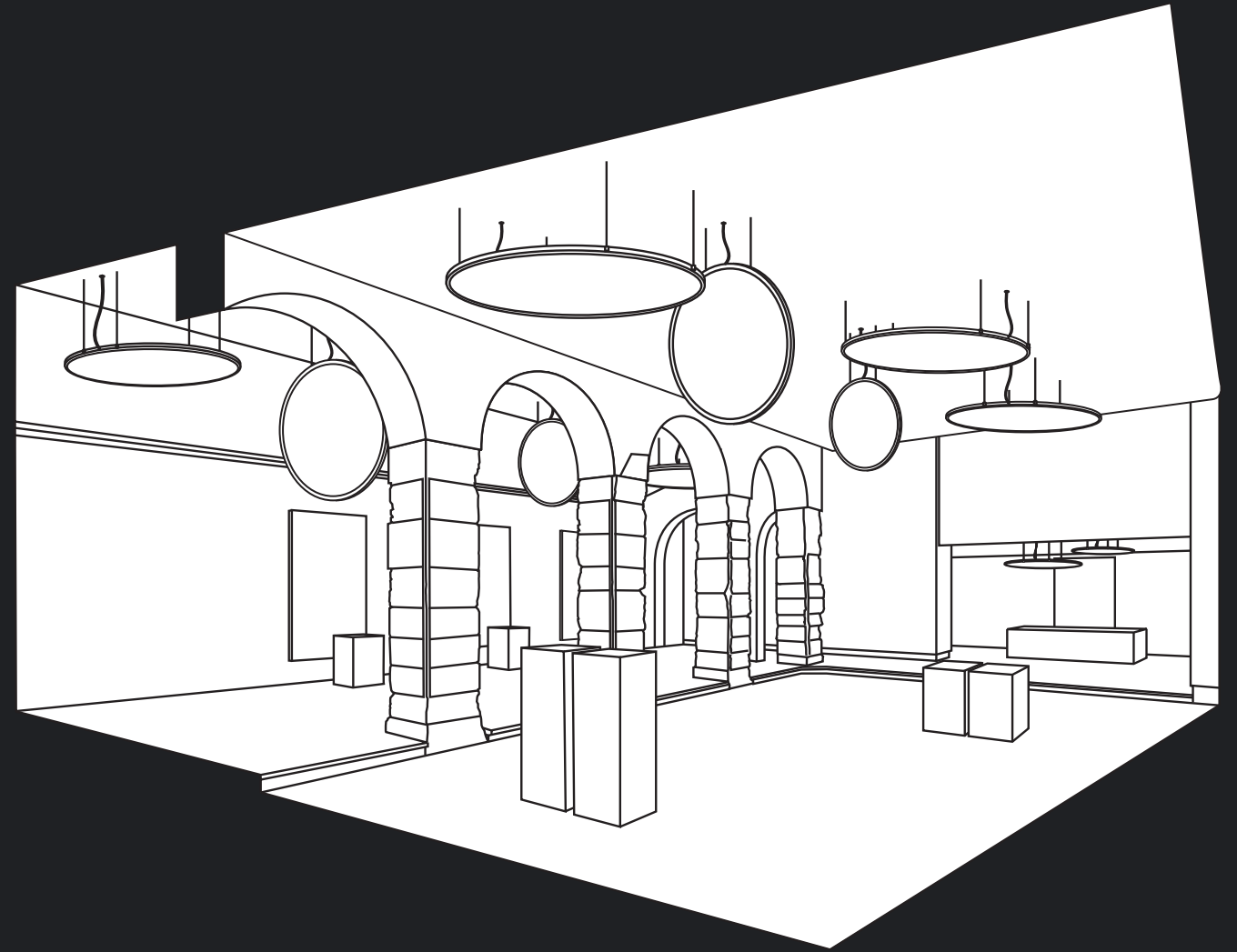

## LIGHT #5

### DUPLO

When the size of the space dictates a need for simplicity in the design of the lighting units. This is the system for architectural lighting that celebrates the absence-essence of substance. Not a lighting unit but vector of illumination.

design by Carlo Zerbaro





**DUPLO**

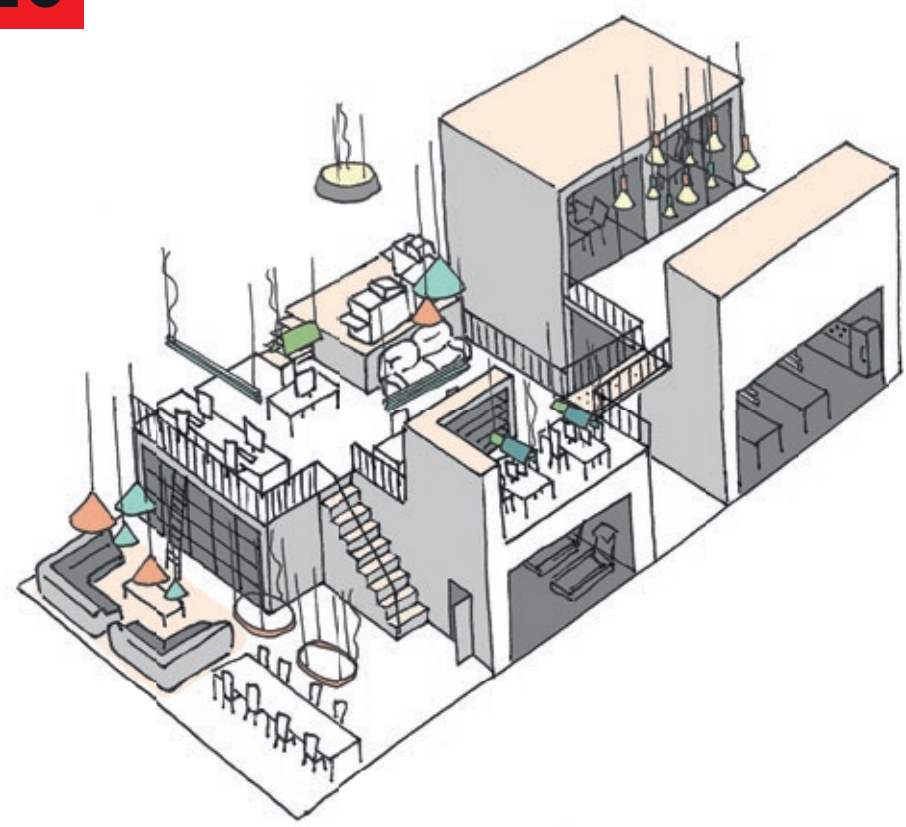



DUPLO

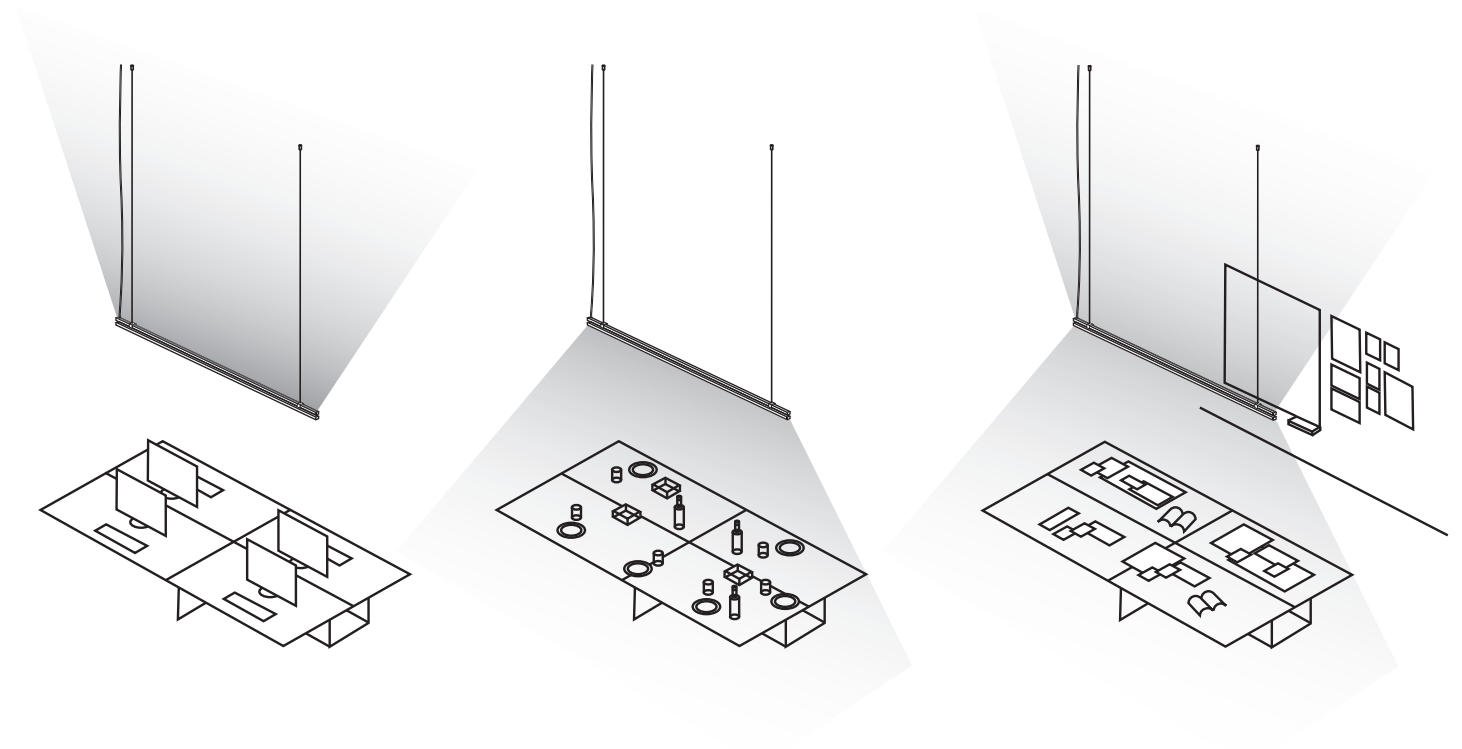

DUPLO

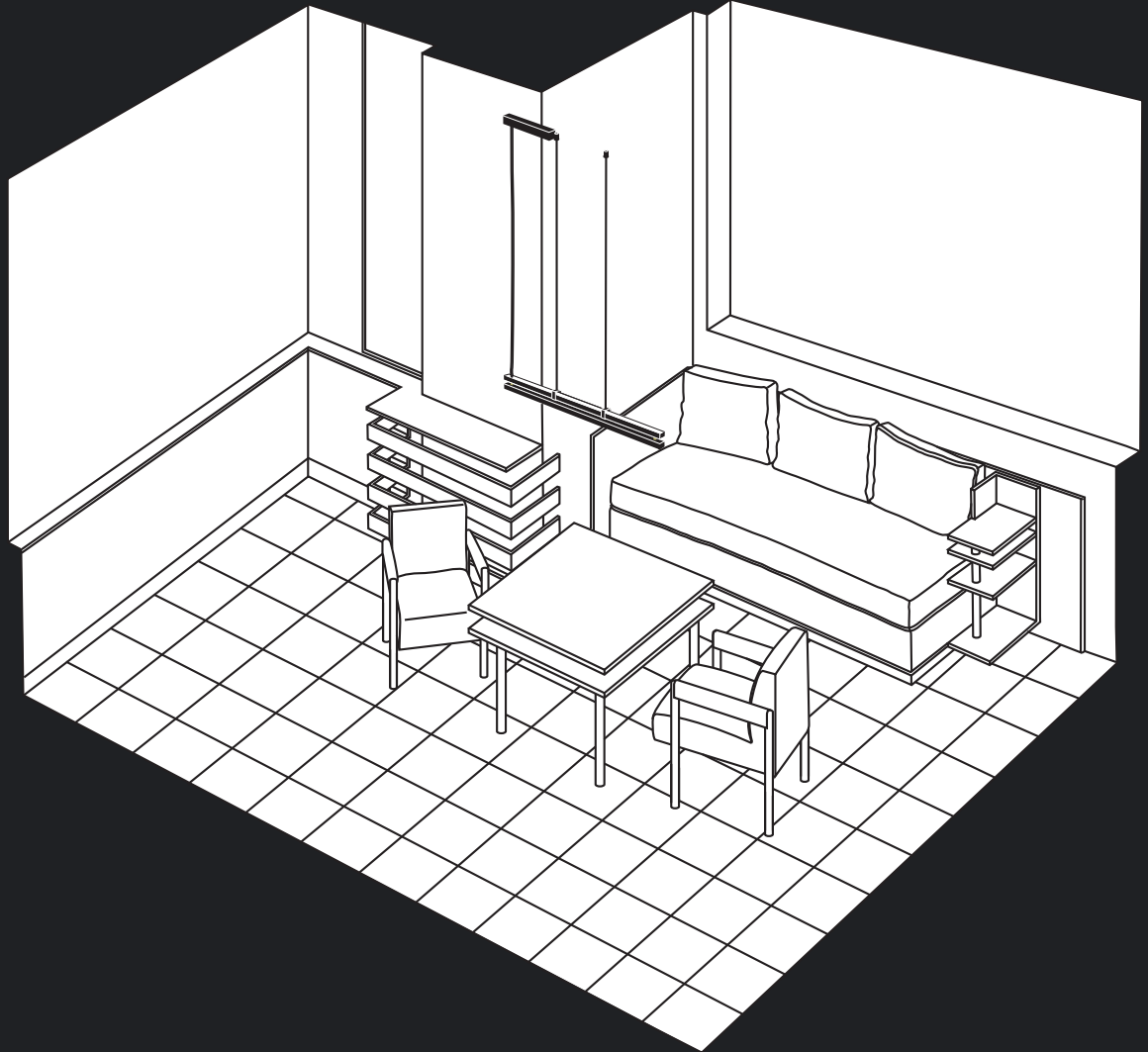





## RITMO

As music, also the design of this lamp shapes spaces using black and white in balanced and unobtrusive proportion.











**RITMO**

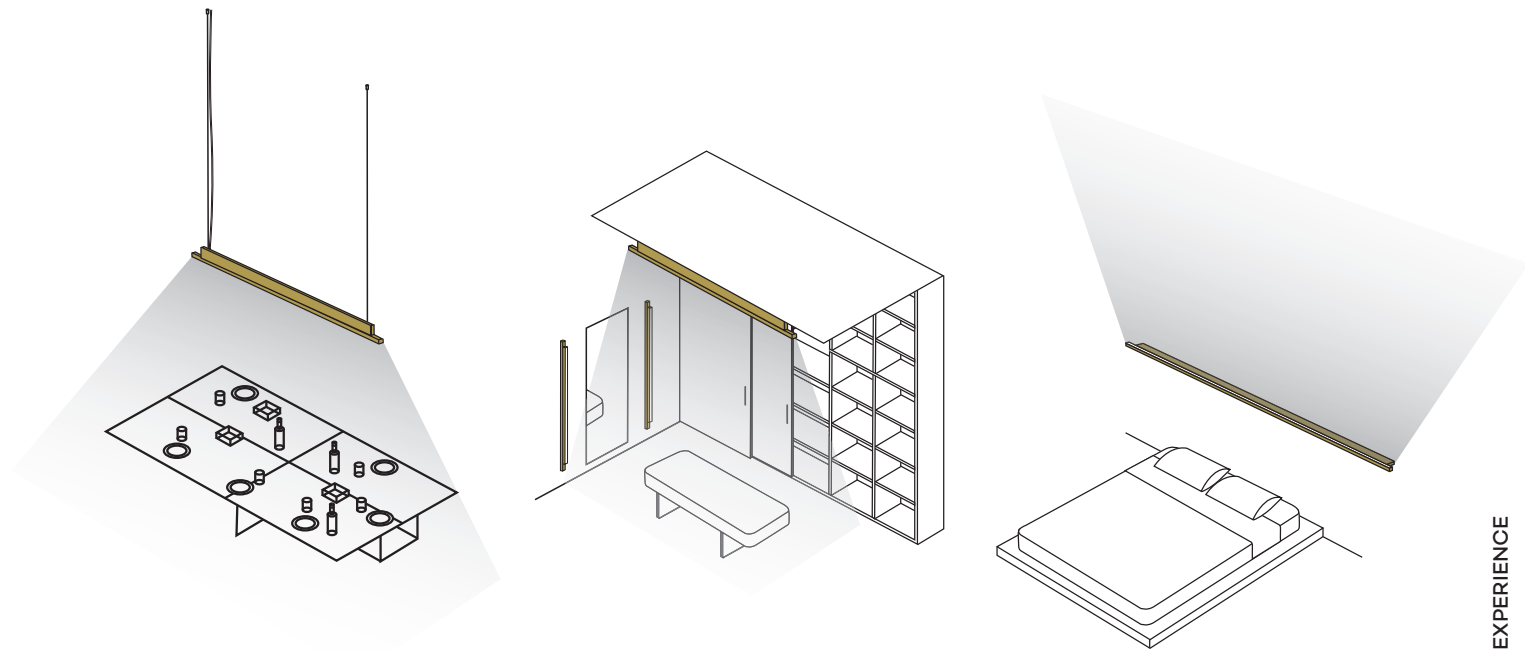

## LIGHT #7

### TESSA

combines lighting function with an excellent acoustic performance. It is extremely versatile and ideal for large spaces, its bell shape minimises external noise levels creating a union between the soft light released and the silence around it.

design by AndCosta R&D







**TESSA**

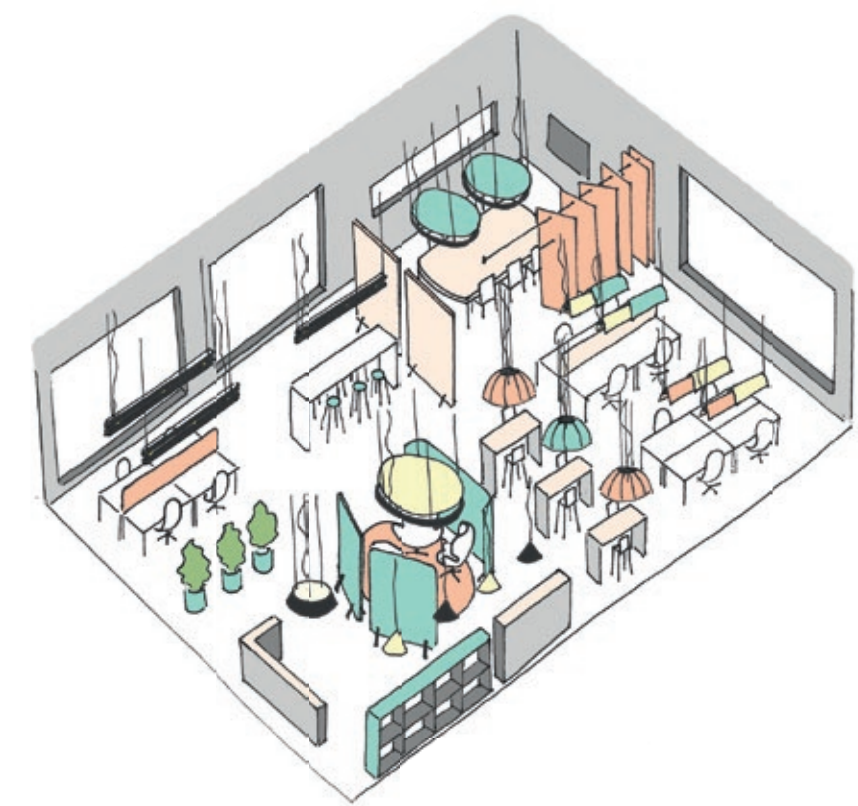



TESSA

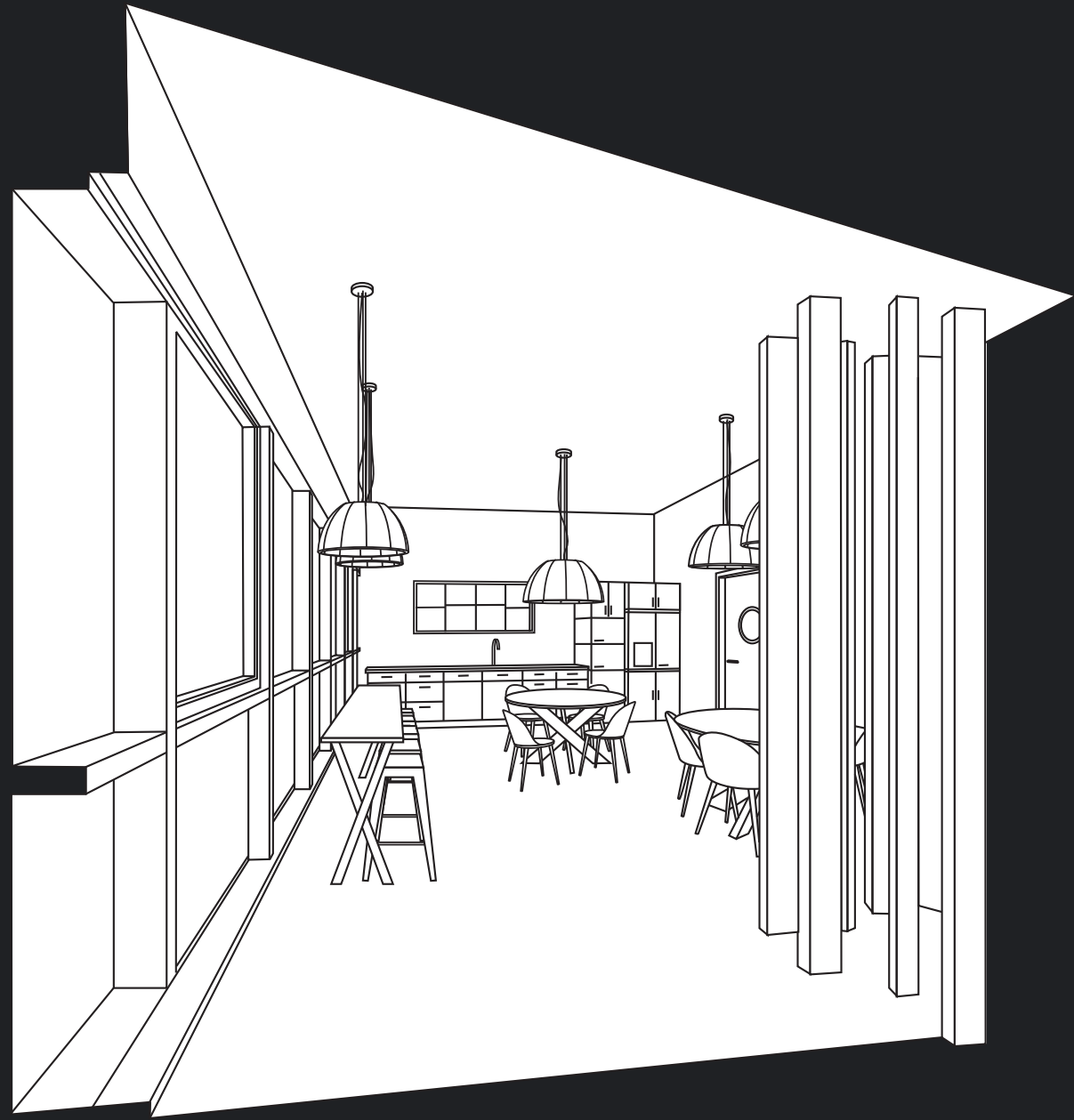



## LIGHT #8

### PIN

The eloquence of primitive geometric shapes create an emblematic and sophisticated silhouette. The softness and opalescent sinuosity of the glass leaks from the metallic body, it is the liberation of a fluid material that becomes a vector of an overwhelming element: light.

design by Cédric Ragot







PIN

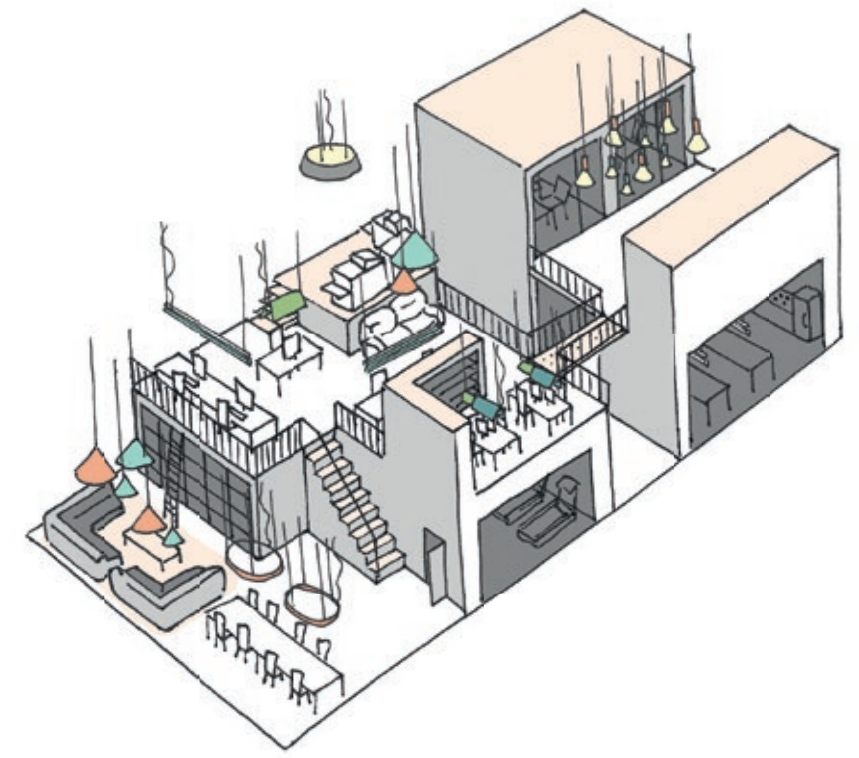







PIN





## ABOUT US



# ANDCOSTA

is based near Venice, an area that loves design and culture, past and present, craftsmanship and beauty. The company Andcosta is a place of research and planning of lighting design. Rooted in the traditions of Italian design, it creates lighting units that reflect functionality and timeless beauty in their style.

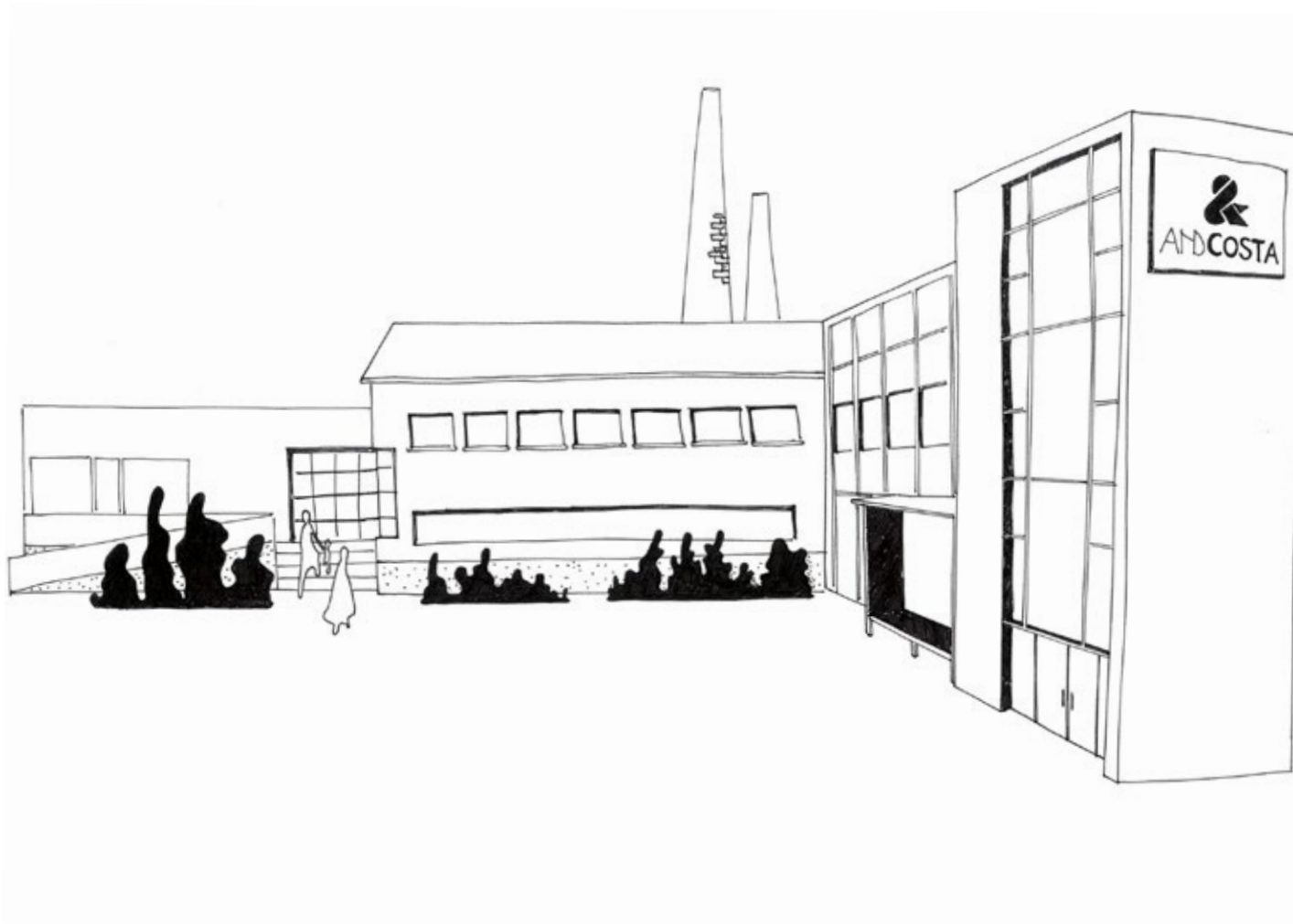

The restoration of this mill building, with its industrial history, has preserved its existing structure, enhancing and adapting its spaces to the requirements of our company.

The industrial architecture was skilfully restored and renovated and its 4000 m<sup>2</sup> of floorspace now host the company's administration offices, the graphics and design team, production and logistics, a photo studio, and showrooms, as well as a meeting and collaboration space.

This site, once dedicated to textile manufacture, is now a design powerhouse of ideas and lighting concepts.



All rights reserved.  
No part of this publication  
may be reproduced, stored  
in a retrieval system  
or transmitted, in any form  
or by any means, electronic,  
mechanical, photocopying,  
recording or otherwise,  
without the prior permission  
of Andcosta.  
Andcosta reserves the right to  
introduce any changes  
to its own model, without  
prior notice.

Graphic design: AndCosta

© AndCosta. All rights reserved.

AndCosta  
via delle Pastorelle 6  
36016 Thiene (VI) ITALY  
tel: +39 0445 873517  
info@ecosta.it  
andcosta.com





